



BMP51

LABEL PRINTER

**Designed to get
the job done**



Designed to get the job done

The Brady Advantage

When it comes to identification, safety and compliance, there's a clear advantage to working with Brady. We put our customers first in everything we do.

Our goal is to give you an unrivalled customer experience. We are relentlessly committed to performance and excellence - in our products, services and people.

Our products and solutions perform in ways that others simply can't match. Our people perform in ways that regularly exceed your expectations, and our focus and discipline work toward solid, long-term performance for our customers.

In short, Brady is the company you trust when performance matters most.

Learn more about the Brady Advantage at: www.bradyeurope.com

Table of contents

3	Designed to get the job done
4	BMP51 at a glance
5	BMP51 Top 3 features
6	Applications
8	Advantages of labelling
9	What is a professional label ?
10	BMP51 Media Offering
11	Font sizes & symbol library
12	Electrical, voice/datacom identification
21	General & industrial identification
26	Laboratory identification
37	Material index
39	Software
41	Printer specifications
42	BMP51 Printer, kits and accessories
43	Brady Technical Service



BMP51
LABEL PRINTER



Brady products are sold on the condition that the purchaser will test them in actual use and determine for himself/herself their suitability to his/her intended purpose. Brady warrants to the purchaser that Brady products are free from defects in material and workmanship but limits its obligation under this warranty to the replacement of the product which has been shown to Brady's satisfaction to have been defective at the time of its purchase.

The warranty does not extend to any persons who have acquired the product from the purchaser. It is in lieu of any other warranty, including every warranty of sale-ability, marketability or suitability for the intended purpose, and is also in lieu of any other obligation or liability on the part of Brady.

Under no circumstances will Brady be liable for losses, damage, costs or subsequent damage of whatever nature which may arise in connection with the use of, or inability to use, Brady's products.

Designed to get the job done

When you need clear, durable labels on the spot, you need the BMP51 Label Printer from Brady. It offers crisp printing, easy formatting, convenient label sizes, and portability required for electrical and datacom installations, laboratory identification, facility and safety labelling.



Get the job done **FASTER.**

Change supplies in seconds. Hassle free drop-in cartridges contain both the label material & ribbon.

Automatic label formatting. Cartridges feature smart cell technology that tells the printer how to correctly format your label. You just drop in a cartridge and the printer calibrates the rest.

Quick to print. Prints 25.40 mm per second – which means no more waiting around for labels to print.

Durable built-in cutter. There's a self-cleaning cutter that can cut through any material with ease, and it even grips the label until you need it.

Get the job done **EASIER.**

Battery options for portability. Use with the AC power supply, AA-batteries or simply with the rechargeable Li-Ion battery which allows you to print over 3,000 labels on a single charge.

Wireless capabilities. Built-in Bluetooth® technology provides a wireless printing option.

Robust software. Brady Workstation enables the printer to print: bar code symbologies, time/date stamps, imported graphics, automatic data serialisation, and more.

Continuous & die-cut label materials

Whether you need to label wires, cables, panels or equipment, you can do it all with this one printer. There are 20 material types and more than 200 label parts to choose from.

Labels up to 38.10 mm wide. Make large labels that can easily be identified from a distance (or make continuous labels up to 1m long!).

Magnet. Keep your printer handy and your hands free. Use the magnet to place your printer on any metal surface.

Get the job done **WITH CONFIDENCE.**

Label for the long haul. Our labels won't fade, smear or fall off – so you only need to label something once.

A rugged printer you can rely on. This printer can survive in all kinds of harsh environments, temperatures and has a rugged, drop tested construction.

BMP51 at a glance

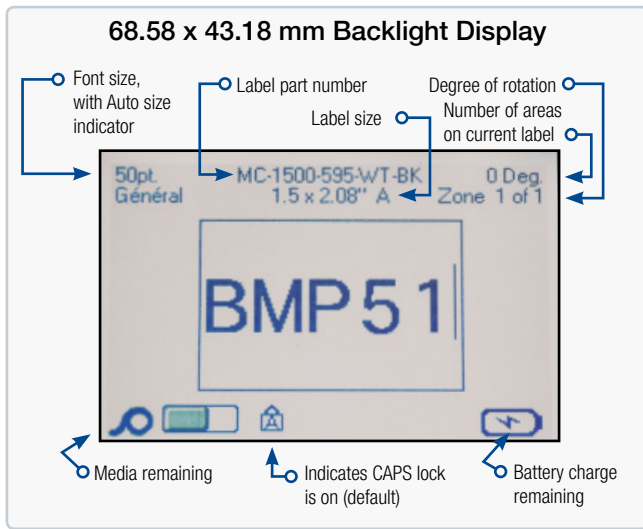

**2 YEAR
WARRANTY**

BMP51 Top 3 features



Connectivity

At built-in Bluetooth card makes it quick & easy to print without being physically connected to a PC.



Get the free app from Apple App Store or Google Play (Search “Brady Express Labels”)



Apple App Store



Google Play

Battery options

3 power options: AA batteries, AC adaptor or rechargeable Li-Ion battery

The printer can be powered through a designated AC power adapter. When the adapter is plugging in, it will also charge the BMP Lithium Ion Battery Pack if one is inserted in the battery compartment (it will not charge AA rechargeable batteries).



Hassle-free drop-in cartridges

Ribbon and label materials in ONE cartridge!

- Install or remove ribbon and material in one easy step
- No need to worry about having the right ribbon for your materials
- Ribbon and material runs out at the same time (less waste!)

Easy-to-load cartridges with “No Jam” technology.

- Top-loading cartridge that snaps into place (you can't load it wrong!)
- Easy access to cartridge for quick changes
- Locking mechanism prevents labels from retracting into cartridge



Applications



Enjoy a more premium labelling experience with optimised Brady Authentic materials

Electrical, voice/datacom identification

Wire & cable marking for twisted pair data cables (UTP, FTP...), fibre optic cables, conductors, computer wires, electrical installation wires & cables, power & ground cables, energy cables...



Flags



QuickFlag



BradyGrip print-on hook material



Tags



Wrap-around labels



Self-laminating labels



Rotating self-laminating labels



Sleeves

Component marking for patch panels, control panels, punch blocks, terminal blocks, breaker boxes, face-plates...



Punch block & patch panel labels

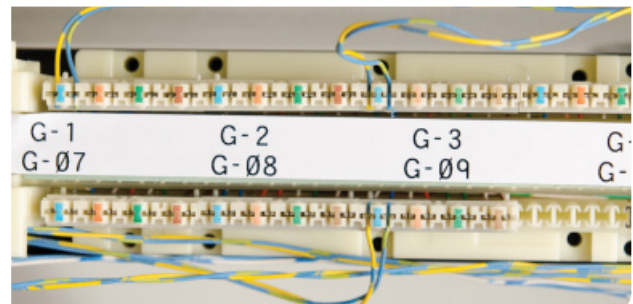

Terminal block labels

General & industrial identification

Asset & component marking to be used on all kind of surfaces (smooth, rough, textured, low energy...).



Rating & name plate labels



Tamper-resistant labels



Labels with pre-printed black border



Enjoy a more premium labelling experience with optimised Brady Authentic materials

Applications

Facility & safety identification

Lean warehouse identification, maintenance labels, temporary warning texts, colour coded storage labeling, tool shadow labels, shelf labeling, ...



Laboratory identification

Specimen tracking identification for sample tracking within histology labs: utilize barcode technology to prevent misdiagnosis.



Straws & rods



Conical & large tube labels

Specimen process marking supporting microscopic analysis of cells and tissues within pathology and clinical labs.



Centrifuge, eppendorf & PCR labels



Slide labels



Tissue cassettes

Specimen storage identification supporting specimen collection and handling such as blood samples, cryo-samples etc.

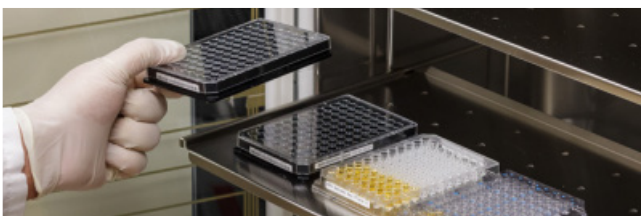

Well plate labels



Cryo labels

Lean lab identification for general supplies marking.



General lab equipment labels



Removable labels for glassware



Bottle tamper seal labels

Advantages of labelling

Ever lost time figuring out where each wire goes?

Durable professional labels that remain legible and stay attached in harsh conditions are extremely important to keep power, network, voice and data cables and components organised and running effectively.

Professional identification on wires, cables and components enables you to:

- immediately recognise what needs checking during troubleshooting
- clearly mark parts for upcoming maintenance upgrades
- trace history, lifespan and supplier
- add safety warnings or precautions

Ask yourself how much time or money you lose while trying to trace an unidentified faulty cable, wire or component.

Ask yourself how fast pressure builds when machinery, production lines, servers and services are impacted.

This is when professional labelling pays off big time.



What is a professional label ?

The combination of label liner, adhesive, substrate and topcoat provide a professional label's features, resistances, capabilities and durability.

- 1 The topcoat gives the label its colour and finish, receives the print, and increases resistance against weathering, flames, chemicals or heat.
- 2 The substrate gives the label its form and provides tensile properties such as strength and flexibility and physical properties such as chemical and temperature resistance.
- 3 The adhesive attaches the label to a chosen surface type and ensures resistance against a set of environmental contexts.
- 4 The label liner is a very thin carrier that releases the self-adhesive label.

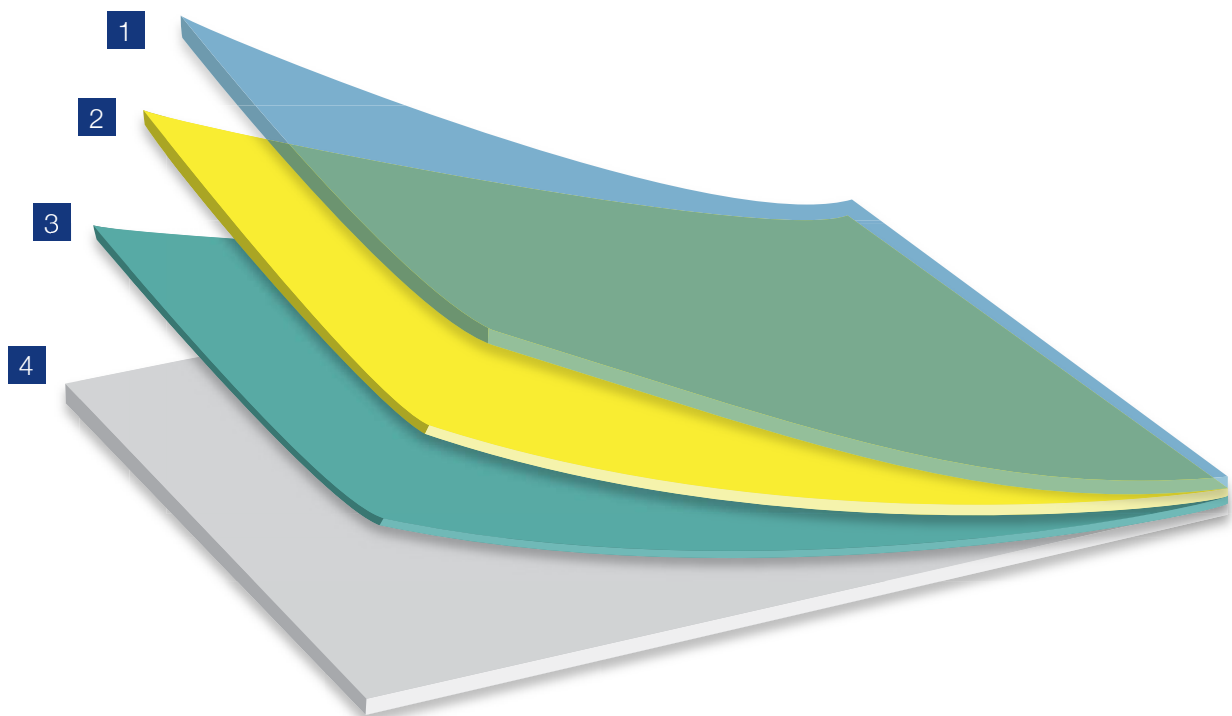

Which label suits your needs best?

Request your Electrical, Tele- & Datacom Identification guide book to help you choose the optimal Brady label material for your application at:

www.bradyeurope.com/cableID.



BMP51 media offering

We continuously try to improve & extend our label material offering, therefore make sure to check for firmware upgrades regularly, in order to make sure you always have access to the newest materials.

Material	
B-109	Polyethylene
B-145	Polyethylene
B-342	Heat-shrink Polyolefin
B-351	Tamper-resistant Vinyl
B-403	Paper
B-412	Polypropylene
B-414	Polyester
B-417	Self-laminating Vinyl
B-422	Polyester
B-425A	Polypropylene
B-427	Self-laminating Vinyl
B-428	Metallised Polyester
B-432	Polyester
B-461	Self-laminating Polyester

Material	
B-481	StainerBondz™ Polyester
B-482	Polyester
B-483A	Polyester
B-488	Polyester
B-490	FreezerBondz™ Polyester
B-492	FreezerBondz™ Polyester
B-494	Polyester
B-498	Vinyl Cloth
B-499	Nylon Cloth
B-584	Reflective Tape
B-595	Vinyl
B-7425	Polypropylene
B-7641	Heat-shrink Polyolefin



Enjoy a more premium labelling experience with optimised Brady Authentic materials

Authentic materials work seamlessly with Brady printers to produce enhanced performance and reliability you just don't get with materials from the others. We've got you covered with the widest range of colours, finishes and targeted applications in the industry. Get authentic. Get better with Brady.

High-performance labeling driven by Brady's Authenticated Technology

Settings are automatically adjusted to the correct material size, type, colour, quantity and compatibility. Brady's Authenticated Technology also sets up optimal burn settings and print speed. Simple and intuitive.

The BMP51 Label Printer works with both M4- and M5-cartridges.



Variable font sizes

Font sizes range from 4 to 103 point.
The maximum font size available depends on factors such as label size, number of characters, number of lines, as well as font sizes in other lines.

Point Size	Print Sample
4	ABC 12345
6	ABC 12345
7	ABC 12345
9	ABC 12345
10	ABC 12345
14	ABC 12345
16	ABC 12345
20	ABC 12345
26	ABC 12345
32	ABC 12345
40	ABC 12345
45	ABC 1234
51	ABC 123
55	ABC 123
60	ABC 123
65	ABC 12
70	ABC 12
76	AB 12
102	AB 12

Font sizes & symbol library

Barcode types



- Code 39 and Code 128
- Other barcodes supported in combination with Brady Workstation

Symbol library

- Standard electrical and datacom symbols
- Over 450 built in graphics
- Built in time/date stamp

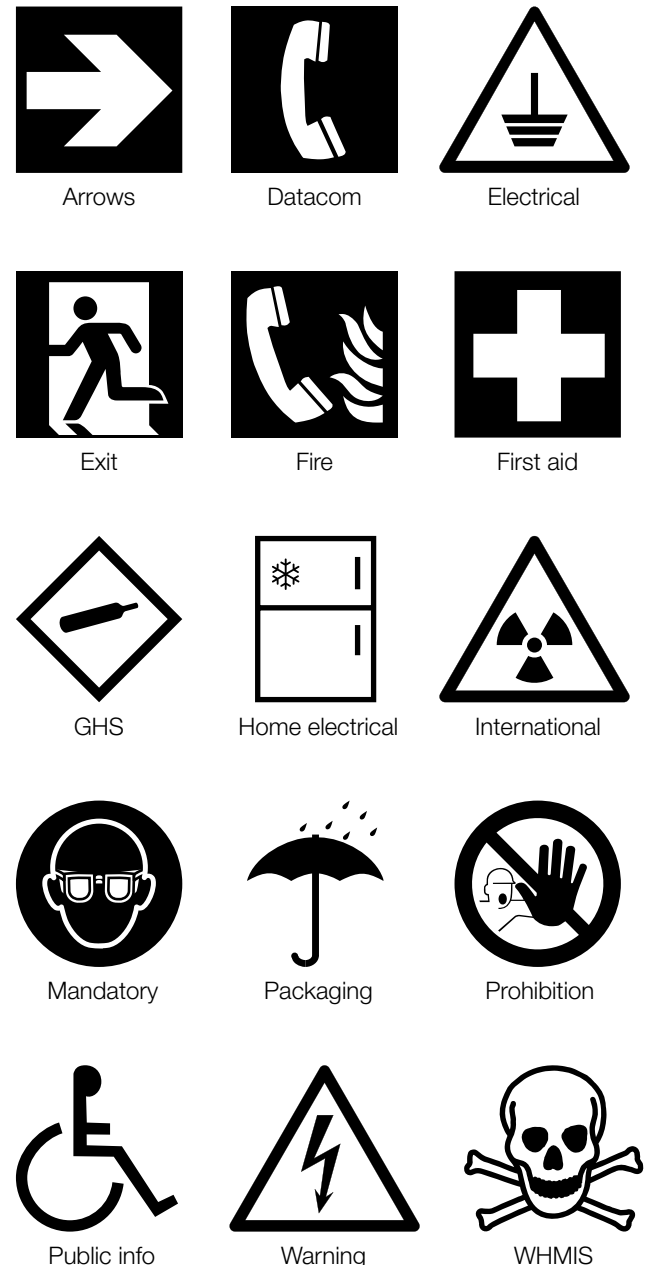

...and many more



Electrical, voice/datacom identification

Wire & cable marking



Cable flags

Pre-formatted with two printable areas, allowing label to be easily folded around wires to create a two-sided, printed flag. Information is still legible on smaller diameter wires and the flag permits you to handle and view labels without touching the wires.

Diagram	Order Reference	Colour	Label Width A (mm)	Label Height B (mm)	Printable Area Height PH (mm)	Labels per Roll
B-425A: Polypropylene						
TL	M5-01-425-FT	Black on White	30.00	40.01	20.02	200
B-499: Nylon Cloth						
☆	M4-141-499	Black on White	25.40	57.15	-	90
☆	M5-152-499	Black on White	38.10	31.75	-	160

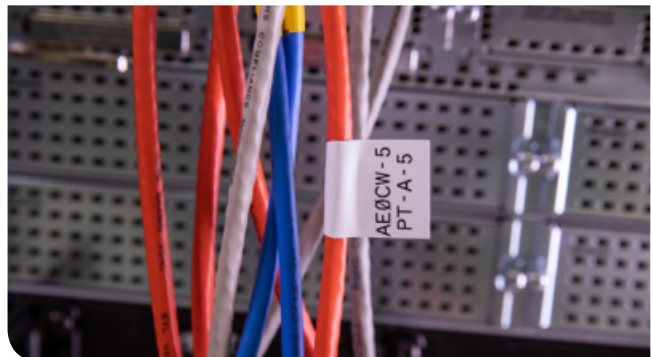
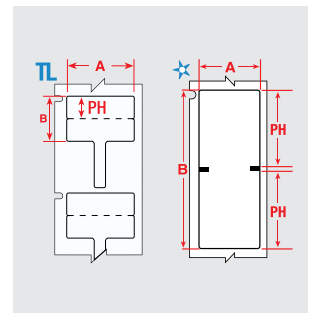

QuickFlag Tapered Wire and Cable Flag Labels

These one-sided labels feature a unique, tapered design so you don't need to align corners, eliminating mismatched edges every time. Brady QuickFlag Labels only carry adhesive on the tapered part of the label, making application almost foolproof and preventing exposed adhesive.

Diagram	Order Reference	Colour	Label Width A (mm)	Label Height B (mm)	Printable Area Height PH (mm)	Printable Area Width PW (mm)	Labels per Roll
B-483A: Polyester							
♣	M4-214-483	Black on White	25.40	50.80	25.40	25.40	140

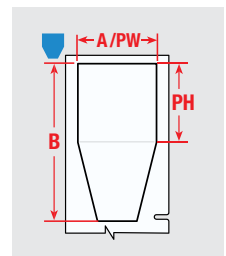

How to read an order reference: example M4-91-427-YL

M4-	91-	427-	YL
M4: Die cut label M4C: Continuous label	Label size code	Brady material number (B-number)	Optional Colour

The BMP51 Label Printer works with both M4- and M5- cartridges.

Electrical, voice/datacom identification

Wire & cable marking

BradyGrip™ print-on hook material

BradyGrip™ Print-on Hook Material is a one-of-a-kind solution that allows identification to be easily printed and placed on bundles.

A grippy backing makes it easy to reposition or remove, so no need for costly rework. Just print on and place - it's that simple.

- Maximises your uptime with faster, printable ID for cable bundles.
- Apply, reposition and remove with exclusive, print-and-place material.
- Offers a non-damaging alternative to nylon cable ties.
- Customise labels to fit big or small jobs by printing on different-width material.



Diagram	Order Reference	Colour	Label Width A (mm)	Label Length B (m)	Recommended Velcro® One-Wrap® size range to use with BradyGrip™ (mm)
B-414: Polyester					
	M4C-250-414	Black on White	6.35	3.66 m	10 - 13
	M4C-500-414	Black on White	12.70	3.66 m	13 - 16
	M4C-750-414	Black on White	19.05	3.66 m	20 - 50

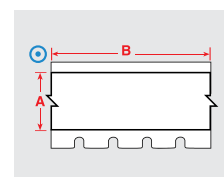

Tags for communications cables

Multi-purpose tag that can be used for a variety of applications including identification of multiconductor cables, inventory, equipment, lockout, safety warning repair and work-in-progress. Extremely tear resistant.

Diagram	Order Reference	Colour	Label Width A (mm)	Label Height B (mm)	Printable Area Width PW (mm)	Printable Area Height PH (mm)	Labels per Roll
B-109: Polyethylene							
	M5-12-109	Black on White	76.20	19.05	55.88	19.05	80
B-145: Polyethylene							
	M5-111-145FR-GY	Black on Grey	30.63	19.05	20.57	19.05	65

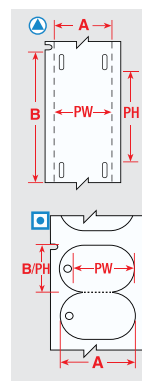

Wrap around wire & cable markers

Durable vinyl cloth wrap around wire and cable markers made with an adhesive that allows the markers to be removed cleanly and reapplied if necessary.

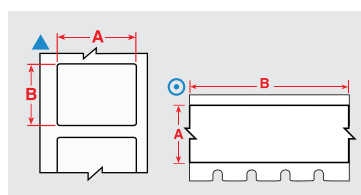

Diagram	Order Reference	Colour	Label Width A (mm)	Label Height B (mm)	Label Length B (m)	Max. Wire Diameter (mm)	Labels per Roll
B-498: Vinyl Cloth							
	M4-7-498	Black on White	12.70	12.70	-	2.80	240
	M4-11-498	Black on White	19.05	12.70	-	4.00	220
	M4-48-498	Black on White	25.40	19.05	-	5.10	180
	M4-49-498	Black on White	25.40	25.40	-	5.10	160
	M4-91-498	Black on White	25.40	38.10	-	7.10	120
B-499: Nylon Cloth							
	M4C-375-499	Black on White	9.53	-	4.88	-	1
	M4C-500-499	Black on White	12.70	-	4.88	-	1
	M4C-750-499	Black on White	19.05	-	4.88	-	1
	M4-131-499	Black on White	25.40	12.70	-	5.10	180
	M5C-1000-499	Black on White	25.40	-	4.88	-	1
	M5C-1500-499	Black on White	38.10	-	4.88	-	1





Electrical, voice/datacom identification

Wire & cable marking



Self-laminating wire & cable markers

Self-laminating markers feature a printable zone in white or yellow and a transparent, non printable area that wraps around wires and cables and serves as an overlamine to the printed text.

- Designed to adhere to highly curved surfaces, wires and cables
- Superior resistance to abrasion, handling, solvents, water, oil, dirt and more

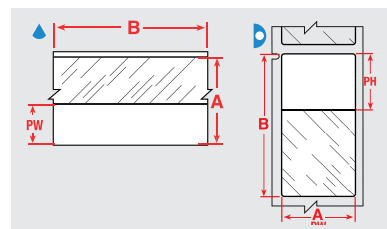

Diagram	Order Reference	Colour	Label Width A (mm)	Label Height B (mm)	Label Length B (m)	Printable Area Width PW (mm)	Printable Area Height PH (mm)	Labels per Roll	Max. Wire Diameter (mm)	For Data Cables Sized to Fit
B-427: Self-laminating Vinyl										
▶	M4-102-427	Black on White, Transparent	12.70	31.75		12.70	9.53	200	7.10	CAT 5, CAT 6
▶	M4-11-427	Black on White, Transparent	12.70	19.05		12.70	9.53	360	3.00	4 Pair UTP Copper, CAT 6
▶	M4-89-427	Black on White, Transparent	12.70	38.10		12.70	12.70	180	8.10	CAT 5, CAT 6
▶	M4-90-427	Black on White, Transparent	19.05	38.10		19.05	12.70	180	8.10	CAT 5, CAT 6
▶	M4-48-427	Black on White, Transparent	19.05	25.40		19.05	9.53	200	3.00	CAT 5, CAT 6
▶	M4-91-427	Black on White, Transparent	25.40	38.10		25.40	12.70	180	8.10	CAT 5, CAT 6
▶	M4-143-427	Black on White, Transparent	25.40	31.75		25.40	12.70	200	6.10	CAT 5, CAT 6
▶	M4-91-427-YL	Black on Yellow, Transparent	25.40	38.10		25.40	12.70	180	8.10	CAT 5, CAT 6
▶	M4-51-427	Black on White, Transparent	25.40	63.50		25.40	19.05	110	14.20	25 Pair Copper, 4-12 pair Fibre, Coaxial
▶	M4-49-427	Black on White, Transparent	25.40	25.40		25.40	9.53	260	5.10	2 Pair Fibre/Coaxial, Single/Multi mode fibre cables
▶	M4-136-427	Black on White, Transparent	25.40	19.05		25.40	9.53	340	3.00	CAT 6, 4 Pair UTP Copper
▶	M4-51-427-YL	Black on Yellow, Transparent	25.40	63.50		25.40	19.05	110	14.20	25 Pair Copper, 4-12 pair Fibre, Coaxial
▶	M4-53-427	Black on White, Transparent	25.40	101.60		25.40	25.40	70	24.30	24 Pair Fibre, Backbone, CAT 7
▶	M4-47-427	Black on White, Transparent	25.40	12.70		25.40	9.53	360	5.10	2 Pair Fibre/Coaxial, Single/Multi mode fibre cables
▶	M4-53-427-YL	Black on Yellow, Transparent	25.40	101.60		25.40	25.40	70	24.30	24 Pair Fibre, Backbone, CAT 7
▶	M5-116-427	Black on White, Transparent	38.10	63.50		38.10	19.05	80	14.20	25 Pair Copper, 4-12 pair Fibre, Coaxial
▶	M5-32-427	Black on White, Transparent	38.10	38.10		38.10	12.70	180	8.10	CAT 5, CAT 6
▶	M5-33-427	Black on White, Transparent	38.10	101.60		38.10	25.40	70	24.30	24 Pair Fibre, Backbone, CAT 7
▶	M5-34-427	Black on White, Transparent	38.10	152.40		38.10	38.10	40	36.40	36 Pair Fibre, Backbone, CAT 3
▲	M4C-750-427	Black on White, Transparent	19.05	-	7.62 m	9.53	-	1	3.00	CAT 5, CAT 6
▲	M5C-1000-427	Black on White, Transparent	25.40	-	7.62 m	9.53	-	1	5.10	CAT 5, CAT 6
▲	M5C-1500-427	Black on White, Transparent	38.10	-	7.62 m	12.70	-	1	8.10	CAT 5, CAT 6

Electrical, voice/datacom identification

Wire & cable marking



High adhesion self-laminating wire & cable markers

B-417 high-adhesion self-laminating vinyl wraps are for tough conditions, including high-humidity environments, small diameter wires and newer wire jacketing materials. Features a white printable area and a clear overlaminating area that protects the print.

- Dependable, long-term adhesion to small diameter wires
- Strong adhesion to a variety of wire jacketing materials, including Teflon™, silicone, braided and traditional PVC

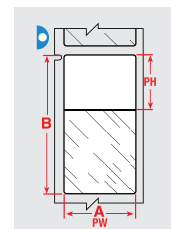

Diagram	Order Reference	Colour	Label Width A (mm)	Label Height B (mm)	Printable Area Width PW (mm)	Printable Area Height PH (mm)	Labels per Roll	Max. Wire Diameter (mm)	For Data Cables Sized to Fit
B-417: Self-laminating Vinyl									
	M-11-417	Black on White, Transparent	12.70	19.05	12.70	9.53	360	3.00	
	M-48-417	Black on White, Transparent	19.05	25.40	19.05	9.53	200	3.00	CAT 5, CAT 6
	M-136-417	Black on White, Transparent	25.40	19.05	25.40	9.53	340	3.00	
	M-49-417	Black on White, Transparent	25.40	25.40	25.40	9.53	260	5.11	2 Pair Fibre/Coaxial, Single/Multi mode fibre cables
	M-143-417	Black on White, Transparent	25.40	31.75	25.40	12.70	200	6.10	CAT 5, CAT 6
	M-91-417	Black on White, Transparent	25.40	38.10	25.40	12.70	180	8.10	CAT 5, CAT 6
	M-51-417	Black on White, Transparent	25.40	63.50	25.40	19.05	110	14.20	25 Pair Copper, 4-12 pair Fibre, Coaxial
	M-116-417	Black on White, Transparent	38.10	63.50	38.10	19.05	80	14.20	25 Pair Copper, 4-12 pair Fibre, Coaxial



Rotating self-laminating wire & cable markers

The B-427 self-laminating rotating label can be rotated around a cable thanks to a non-adhesive printable zone and a translucent, self-adhesive laminate that is wrapped around a cable. The rotating label spins freely around Cat 5 and fiber optic cables, making it easy to read its print from any angle.

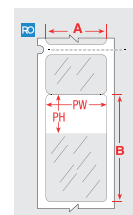
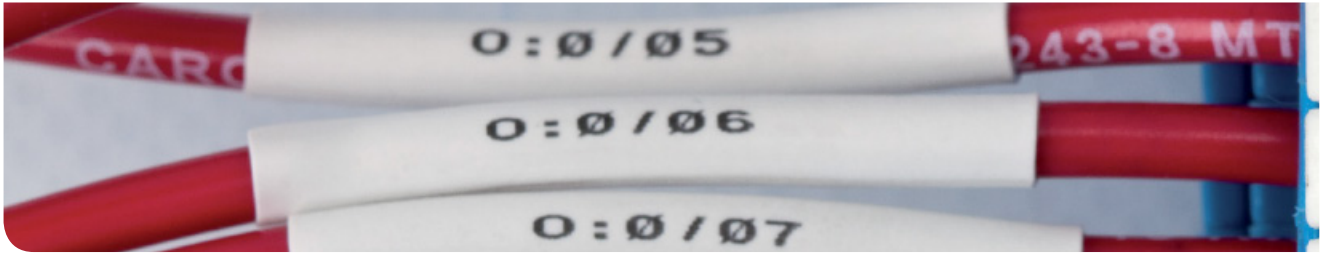

Diagram	Order Reference	Colour	Label Width A (mm)	Label Height B (mm)	Printable Area Width PW (mm)	Printable Area Height PH (mm)	Labels per Roll	Max. Wire Diameter (mm)
B-427: Self-laminating Vinyl								
	M4-206-RO-427	Black on White, Transparent	12.70	44.45	12.70	17.78	110	5.13
	M4-207-RO-427	Black on White, Transparent	12.70	69.85	12.70	27.94	70	8.07
	M4-203-RO-427	Black on White, Transparent	25.40	44.45	25.40	17.78	110	5.13
	M4-211-RO-427	Black on White, Transparent	25.40	30.48	25.40	12.70	150	3.65
	M4-209-RO-427	Black on White, Transparent	25.40	69.85	25.40	27.94	70	8.07



Electrical, voice/datacom identification

Wire & cable marking



PermaSleeve PS wire marking sleeves

These heat-shrink sleeves are the ultimate in marker durability, permanence and aesthetic appearance. Fast shrink rate saves time and costs during installation. Available as individual die-cut markers or continuous cut-to-length tubing.

Diagram	Order Reference	Colour	Label Width A (mm)	Label Height B (mm)	Label Length B (m)	Min. Wire Diameter (mm)	Max. Wire Diameter (mm)	Labels per Roll
B-342: Heat-shrink Polyolefin								
V	M4-187-075-342	Black on White	19.05	8.51	–	1.57	3.81	80
V	M4-250-075-342	Black on White	19.05	11.15	–	2.39	5.46	80
V	M4-125-075-342	Black on White	19.05	5.97	–	1.17	2.79	80
V	M4-375-075-342	Black on White	19.05	16.38	–	3.18	8.13	80
V	M5-125-1-342	Black on White	25.40	5.97	–	1.17	2.79	80
V	M5-187-1-342	Black on White	25.40	8.51	–	1.57	3.81	80
V	M5-250-1-342	Black on White	25.78	11.15	–	2.39	5.46	80
⊙	M4C-125-342	Black on White	–	5.97	2.13 m	1.17	2.79	1
⊙	M4C-125-342-YL	Black on Yellow	–	5.97	2.13 m	1.17	2.79	1
⊙	M4C-187-342	Black on White	–	8.51	2.13 m	1.57	3.81	1
⊙	M4C-187-342-YL	Black on Yellow	–	8.51	2.13 m	1.57	3.81	1
⊙	M4C-250-342	Black on White	–	11.15	2.13 m	2.39	5.46	1
⊙	M4C-250-342-YL	Black on Yellow	–	11.15	2.13 m	2.39	5.46	1
⊙	M4C-375-342	Black on White	–	16.38	2.13 m	3.18	8.13	1
V	M5-375-1-342	Black on White	25.40	16.38	–	3.18	8.13	80

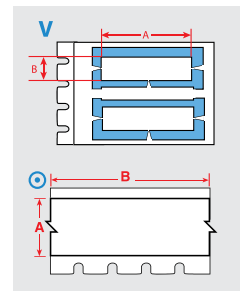

PermaSleeve Low Smoke Zero Halogen Heat-Shrink Sleeve Markers

These heat-shrink sleeves are the ultimate in marker identification, protection, durability and aesthetic appearance. Fast shrink rate saves time and costs during installation. Low smoke zero halogen wire marking sleeves (B-7641) offer outstanding fire safety properties and minimal smoke emission.

Diagram	Order Reference	Colour	Label Width A (mm)	Label Length B (m)	Min. Wire Diameter (mm)	Max. Wire Diameter (mm)	Labels per Roll
B-7641: Heat-shrink Polyolefin							
♥	M4C-125-7641	Black on White	5.97	1.68	1.57	2.79	1
♥	M4C-125-7641-YL	Black on Yellow	5.97	1.68	1.57	2.79	1
♥	M4C-187-7641	Black on White	8.51	1.68	2.39	3.81	1
♥	M4C-187-7641-YL	Black on Yellow	8.51	1.68	2.39	3.81	1
♥	M4C-250-7641	Black on White	11.15	1.68	3.18	5.46	1
♥	M4C-250-7641-YL	Black on Yellow	11.15	1.68	3.18	5.46	1
♥	M4C-375-7641	Black on White	16.38	1.68	4.78	8.13	1
♥	M4C-375-7641-YL	Black on Yellow	16.38	1.68	4.78	8.13	1

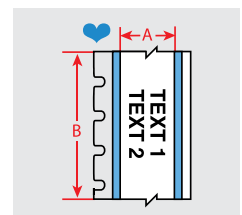

Electrical, voice/datacom identification

Component Marking



Punch block & patch panel labels

Make fully-formatted punch block strips or labels in one easy process. Using Brady Workstation labelling software easily create serialised punch block labels with or without grid lines to fit your equipment.

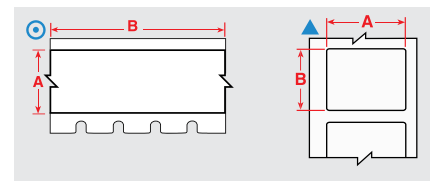

Diagram	Order Reference	Colour	Label Width A (mm)	Label Height B (mm)	Label Length B (m)	Labels per Roll	Additional Features
B-412: Polypropylene							
⊙	M4C-375-412	Black on White	9.53	–	6.10 m	1	Non-Adhesive Slide-in Strips
⊙	M4C-475-412	Black on White	12.07	–	6.10 m	1	Non-Adhesive Slide-in Strips
⊙	M4C-625-412	Black on White	15.88	–	6.10 m	1	Non-Adhesive Slide-in Strips
B-422: Polyester							
▲	M4-7-422	Black on White	12.70	12.70		280	Port Labels
⊙	M4C-375-422	Black on White	9.53	–	7.62 m	1	Adhesive Stick-on Strips: Outlet, Patch Panel, Cont. Tape, Cut to Size
⊙	M4C-475-422	Black on White	12.07	–	7.62 m	1	Adhesive Stick-on Strips: Outlet, Patch Panel, Cont. Tape, Cut to Size
⊙	M4C-625-422	Black on White	15.88	–	7.62 m	1	Adhesive Stick-on Strips: Outlet, Patch Panel, Cont. Tape, Cut to Size

Terminal block markers

Specially-designed narrow-width markers. Brady Workstation labelling software can auto-serialise these labels to save you time.

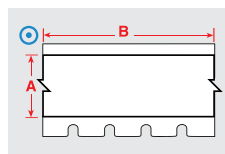

Diagram	Order Reference	Colour	Label Width A (mm)	Label Length B (m)	Labels per Roll
B-498: Vinyl Cloth					
⊙	M4C-240-498	Black on White	6.10	4.88 m	1
⊙	M4C-318-498	Black on White	8.08	4.88 m	1
⊙	M4C-375-498	Black on White	9.53	6.10 m	1



Did you know?

The BMP51 Label printer has a built-in label retention feature, that grips the label until you need it. Paired with the magnet accessory, this is the ultimate answer to your “on the job” labelling requirements.

Electrical, voice/datacom identification

Component marking



General datacom identification

Durable materials with permanent adhesive. Available in a variety of sizes and colours for marking racks, bays, frames, slots, and other voice/data hardware.

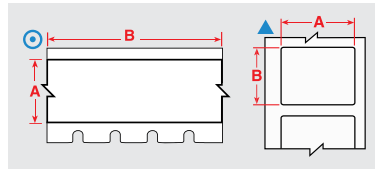

Diagram	Order Reference	Colour	Label Width A (mm)	Label Height B (mm)	Label Length B (m)	Labels per Roll	Additional Features
B-422: Polyester							
▲	M4-7-422	Black on White	12.70	12.70	–	280	Port Labels
▲	M4-89-422	Black on White	12.70	38.10	–	180	Adhesive Stick-on individual labels
⊙	M4C-1000-422	Black on White	25.40	–	7.62 m	1	Adhesive Stick-on Strips: Outlet, Patch Panel, Cont. Tape, Cut to Size
▲	M4-49-422	Black on White	25.40	25.40	–	260	Adhesive Stick-on individual labels
B-483A: Polyester							
▲	M4-61-483	Black on White	12.70	50.80	–	80	Ultra-aggressive adhesive; Designed for powder coated surfaces
▲	M4-60-483	Black on White	25.40	50.80	–	140	Ultra-aggressive adhesive; Designed for powder coated surfaces
▲	M4-47-483	Black on White	25.40	12.70	–	480	Ultra-aggressive adhesive; Designed for powder coated surfaces
B-595: Vinyl							
⊙	M4C-375-595-WT-BK	Black on White	9.53	–	7.62 m	1	Adhesive Stick-on Strips, Cut to Size
▲	M4-7-595	Black on White	12.70	12.70	–	280	Adhesive Stick-on individual labels
▲	M4-11-595	Black on White	12.70	19.05	–	360	Adhesive Stick-on individual labels
▲	M4-17-595	Black on White	25.40	12.70	–	360	Adhesive Stick-on individual labels
▲	M4-49-595	Black on White	25.40	25.40	–	160	Adhesive Stick-on individual labels
▲	M5-31-595	Black on White	38.10	25.40	–	250	Adhesive Stick-on individual labels
⊙	M4C-375-595-YL-BK	Black on Yellow	9.53	–	7.62 m	1	Adhesive Stick-on Strips, Cut to Size
⊙	M4C-500-595-YL-BK	Black on Yellow	12.70	–	7.62 m	1	Adhesive Stick-on Strips, Cut to Size
⊙	M4C-750-595-YL-BK	Black on Yellow	19.05	–	7.62 m	1	Adhesive Stick-on Strips, Cut to Size
⊙	M4C-1000-595-YL-BK	Black on Yellow	25.40	–	7.62 m	1	Adhesive Stick-on Strips, Cut to Size
⊙	M5C-1500-595-YL-BK	Black on Yellow	38.10	–	7.62 m	1	Adhesive Stick-on Strips, Cut to Size
⊙	M4C-375-595-RD-WT	White on Red	9.53	–	7.62 m	1	Adhesive Stick-on Strips, Cut to Size
⊙	M4C-500-595-CL-WT	White on Transparent	12.70	–	6.10 m	1	Adhesive Stick-on Strips, Cut to Size
⊙	M4C-750-595-CL-WT	White on Transparent	19.05	–	6.10 m	1	Adhesive Stick-on Strips, Cut to Size
⊙	M4C-1000-595-CL-WT	White on Transparent	25.40	–	6.10 m	1	Adhesive Stick-on Strips, Cut to Size
⊙	M5C-1500-595-CL-WT	White on Transparent	38.10	–	6.10 m	1	Adhesive Stick-on Strips, Cut to Size



Enjoy a more premium labelling experience with optimised Brady Authentic materials

Wire, Asset and Component Identification

From aggressive adhesive labels to high tensile strength tags, get Brady labels to wrap, tag and permanently identify wires, cables and equipment in all environments.

The right label from the right partner.



Electrical, voice/datacom identification

Component marking



General electrical component marking

Various sizes, colours and label types for marking relays, solenoids, switches, drive motors, and other components.

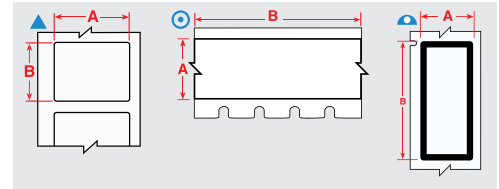

Diagram	Order Reference	Colour	Label Width A (mm)	Label Height B (mm)	Label Length B (m)	Labels per Roll
B-422: Polyester						
⊙	M4C-1000-422	Black on White	25.40	–	7.62 m	1
⊙	M5C-1500-422	Black on White	38.10	–	7.62 m	1
▲	M4-7-422	Black on White	12.70	12.70	–	280
▲	M4-89-422	Black on White	12.70	38.10	–	180
▲	M4-49-422	Black on White	25.40	25.40	–	260
B-428: Metallised Polyester						
◀	M4-92-428-BB	Black on Light Grey	12.70	28.70	–	239
▲	M4-47-428	Black on Light Grey	25.40	12.70	–	480
▲	M4-60-428	Black on Light Grey	25.40	50.80	–	140
▲	M5-29-428	Black on Light Grey	38.10	12.70	–	360
▲	M5-30-428	Black on Light Grey	38.10	19.05	–	260
B-483A: Polyester						
▲	M4-61-483	Black on White	12.70	50.80	–	80
▲	M4-60-483	Black on White	25.40	50.80	–	140
B-499: Nylon Cloth						
▲	M4-11-499	Black on White	19.05	12.70	–	220
▲	M5-84-499	Black on White	22.86	12.70	–	200
▲	M5-132-499	Black on White	38.10	31.75	–	160
▲	M4-128-499	Black on White	48.26	25.40	–	100
B-595: Vinyl						
⊙	M4C-375-595-RD-WT	White on Red	9.53	–	7.62 m	1
⊙	M4C-500-595-OR-BK	Black on Orange	12.70	–	7.62 m	1
⊙	M4C-750-595-OR-BK	Black on Orange	19.05	–	7.62 m	1
⊙	M4C-1000-595-OR-BK	Black on Orange	25.40	–	7.62 m	1
⊙	M5C-1500-595-OR-BK	Black on Orange	38.10	–	7.62 m	1
▲	M4-7-595	Black on White	12.70	12.70	–	280
▲	M4-11-595	Black on White	12.70	19.05	–	360
▲	M4-17-595	Black on White	25.40	12.70	–	360
▲	M4-49-595	Black on White	25.40	25.40	–	160
▲	M5-31-595	Black on White	38.10	25.40	–	250



Electrical, voice/datacom identification

Component marking



Faceplate & outlet labels

Label your ports, jacks, and outlets with a variety of adhesive labels or slide-in strips.

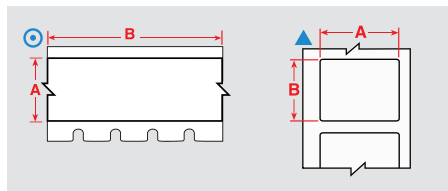

Diagram	Order Reference	Colour	Label Width A (mm)	Label Height B (mm)	Label Length B (m)	Labels per Roll	Additional Features
B-412: Polypropylene							
⊙	M4C-475-412	Black on White	12.07	–	6.10 m	1	Non-Adhesive Slide-in Strips
B-422: Polyester							
⊙	M4C-375-422	Black on White	9.53	–	7.62 m	1	Adhesive Stick-on Strips: Outlet, Patch Panel, Cont. Tape, Cut to Size
⊙	M4C-475-422	Black on White	12.07	–	7.62 m	1	Adhesive Stick-on Strips: Outlet, Patch Panel, Cont. Tape, Cut to Size
▲	M4-7-422	Black on White	12.70	12.70	–	280	Port Labels
▲	M4-89-422	Black on White	12.70	38.10	–	180	Adhesive Stick-on individual labels
B-483A: Polyester							
▲	M4-61-483	Black on White	12.70	50.80	–	80	Ultra-aggressive adhesive; Designed for powder coated surfaces



Control panel and electrical panel labels

Long-lasting, durable materials to quickly identify control and electrical panels.

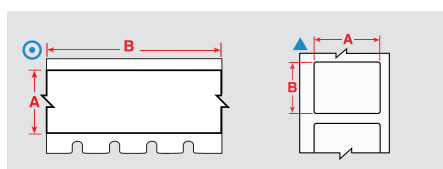

Diagram	Order Reference	Colour	Label Width A (mm)	Label Height B (mm)	Label Length B (m)	Labels per Roll
B-428: Metallised Polyester						
▲	M4-47-428	Black on Light Grey	25.40	12.70	–	480
▲	M4-60-428	Black on Light Grey	25.40	50.80	–	140
▲	M5-29-428	Black on Light Grey	38.10	12.70	–	360
▲	M5-30-428	Black on Light Grey	38.10	19.05	–	260
B-595: Vinyl						
⊙	M5C-1500-595-CL-BK	Black on Transparent	38.10	–	6.10 m	1
⊙	M5C-1500-595-CL-WT	White on Transparent	38.10	–	6.10 m	1
⊙	M4C-375-595-RD-WT	White on Red	9.53	–	7.62 m	1
⊙	M5C-1500-595-BL-WT	White on Blue	38.10	–	7.62 m	1
⊙	M5C-1500-595-GN-WT	White on Green	38.10	–	7.62 m	1
⊙	M5C-1500-595-OR-BK	Black on Orange	38.10	–	7.62 m	1
⊙	M5C-1500-595-RD-WT	White on Red	38.10	–	7.62 m	1
⊙	M5C-1500-595-WT-BK	Black on White	38.10	–	7.62 m	1
⊙	M5C-1500-595-WT-RD	Red on White	38.10	–	7.62 m	1
⊙	M5C-1500-595-YL-BK	Black on Yellow	38.10	–	7.62 m	1
⊙	M5C-1500-595-BK-WT	White on Black	38.10	–	7.62 m	1

General & industrial identification

Asset & component marking



Tamper-resistant labels

Destructible vinyl material prohibits one piece removal of label to indicate if the label has been tampered with.

Diagram	Order Reference	Colour	Label Width A (mm)	Label Height B (mm)	Labels per Roll
B-351: Tamper-resistant Vinyl					
▲	M5-17-351	Black on White	25.40	12.70	360
▲	M5-20-351	Black on White	25.40	50.80	160

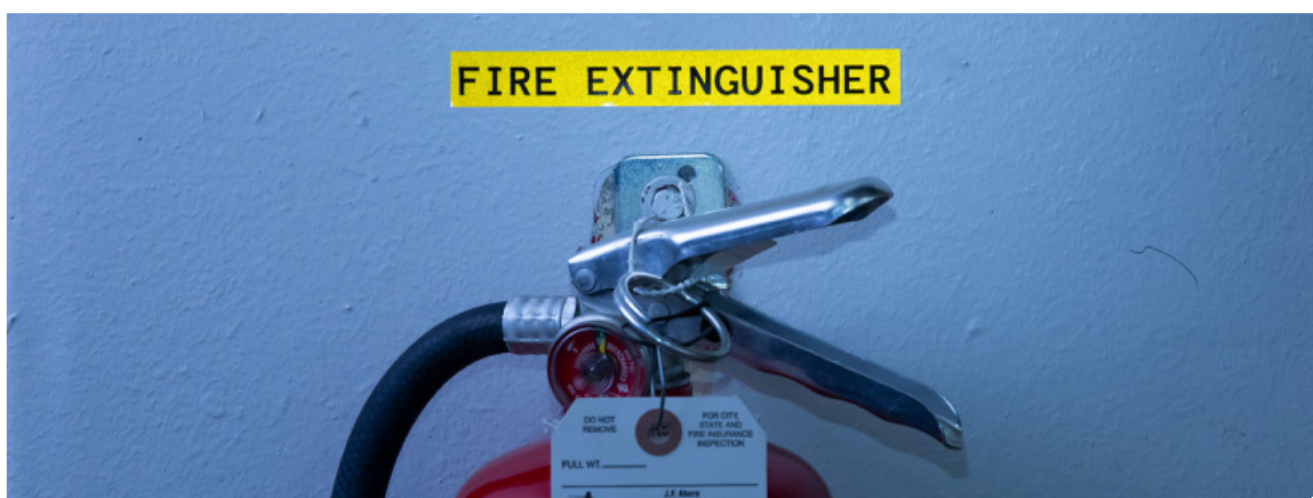
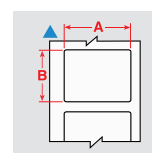

Highly reflective identification

Ideal for reading labels in low light conditions.

Diagram	Order Reference	Colour	Label Width A (mm)	Label Length B (m)	Labels per Roll
B-584: Reflective Tape					
⊙	M4C-500-584	Black on White	12.70	6.10 m	1
⊙	M4C-750-584	Black on White	19.05	6.10 m	1
⊙	M5C-1000-584	Black on White	25.40	6.10 m	1
⊙	M5C-1500-584	Black on White	38.10	6.10 m	1
⊙	M4C-500-584-YL	Black on Yellow	12.70	6.10 m	1
⊙	M4C-750-584-YL	Black on Yellow	19.05	6.10 m	1
⊙	M5C-1000-584-YL	Black on Yellow	25.40	6.10 m	1
⊙	M5C-1500-584-YL	Black on Yellow	38.10	6.10 m	1

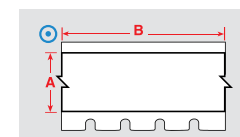



General & industrial identification

Asset & component marking



Name & rating plate labels for rough surfaces

Rough, glossy and irregular surfaces are no match for the ToughBond® ultra aggressive polyester label material.

Diagram	Order Reference	Colour	Label Width A (mm)	Label Height B (mm)	Labels per Roll
B-483A: Polyester					
▲	M4-61-483	Black on White	12.70	50.80	80
▲	M4-60-483	Black on White	25.40	50.80	140
▲	M4-47-483	Black on White	25.40	12.70	480

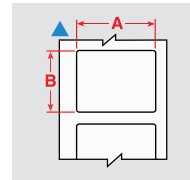

Name & rating plate labels for smooth, high surface energy surfaces

Create tough serial and rating plate labels with the B-428 metalised polyester label material with flexible high-tack adhesive.

Diagram	Order Reference	Colour	Label Width A (mm)	Label Height B (mm)	Labels per Roll
B-428: Metallised Polyester					
▲	M4-92-428-BB	Black on Light Grey	12.70	28.70	239
▲	M-92-428-BB	Black on Light Grey	12.70	33.02	239
▲	M4-47-428	Black on Light Grey	25.40	12.70	480
▲	M4-60-428	Black on Light Grey	25.40	50.80	140
▲	M5-29-428	Black on Light Grey	38.10	12.70	360
▲	M5-30-428	Black on Light Grey	38.10	19.05	260

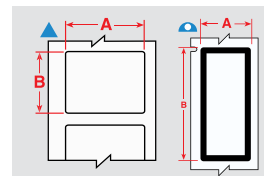

General & industrial identification

Asset & Component Marking



Name & rating plate labels for smooth, low surface energy & textured surfaces

Diagram	Order Reference	Colour	Label Width A (mm)	Label Height B (mm)	Label Length B (m)	Labels per Roll
B-422: Polyester						
⊙	M4C-375-422	Black on White	9.53	–	7.62 m	1
⊙	M4C-475-422	Black on White	12.07	–	7.62 m	1
⊙	M4C-500-422	Black on White	12.70	–	7.62 m	1
▲	M4-7-422	Black on White	12.70	12.70	–	280
▲	M4-89-422	Black on White	12.70	38.10	–	180
⊙	M4C-625-422	Black on White	15.88	–	7.62 m	1
⊙	M4C-1000-422	Black on White	25.40	–	7.62 m	1
▲	M4-47-422	Black on White	25.40	12.70	–	480
▲	M4-49-422	Black on White	25.40	25.40	–	260
▲	M4-90-422	Black on White	38.10	19.05	–	180
B-432: Polyester						
▲	M5-17-432-CL-BK	Black on Transparent	25.40	12.70	–	280
▲	M5-78-432-CL-BK	Black on Transparent	25.40	48.26	–	100
B-499: Nylon Cloth						
⊙	M4C-375-499	Black on White	9.53	–	4.88 m	1
⊙	M4C-500-499	Black on White	12.70	–	4.88 m	1
⊙	M4C-750-499	Black on White	19.05	–	4.88 m	1
▲	M4-11-499	Black on White	19.05	12.70	–	220
▲	M5-84-499	Black on White	22.86	12.70	–	200
⊙	M5C-1000-499	Black on White	25.40	–	4.88 m	1
▲	M5-132-499	Black on White	38.10	31.75	–	160

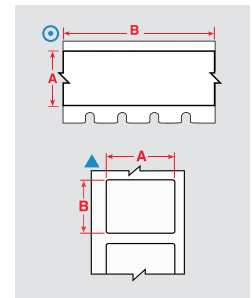



General & industrial identification

Facility identification, General ID, Safety labeling and LEAN 5S



Create a colour-coded LEAN work environment with these durable labeling materials

Diagram	Order Reference	Colour	Label Width A (mm)	Label Height B (mm)	Label Length B (m)	Labels per Roll
B-584: Reflective Tape						
⊙	M5C-1500-584	Black on White	38.10	–	6.10 m	1
⊙	M5C-1500-584-YL	Black on Yellow	38.10	–	6.10 m	1
B-595: Vinyl						
⊙	M4C-500-595-OR-BK	Black on Orange	12.70	–	7.62 m	1
⊙	M4C-750-595-OR-BK	Black on Orange	19.05	–	7.62 m	1
⊙	M4C-1000-595-OR-BK	Black on Orange	25.40	–	7.62 m	1
⊙	M5C-1500-595-OR-BK	Black on Orange	38.10	–	7.62 m	1
⊙	M4C-500-595-CL-BK	Black on Transparent	12.70	–	6.10 m	1
⊙	M4C-750-595-CL-BK	Black on Transparent	19.05	–	6.10 m	1
⊙	M4C-1000-595-CL-BK	Black on Transparent	25.40	–	6.10 m	1
⊙	M5C-1500-595-CL-BK	Black on Transparent	38.10	–	6.10 m	1
⊙	M4C-375-595-WT-BK	Black on White	9.53	–	7.62 m	1
⊙	M4C-500-595-WT-BK	Black on White	12.70	–	7.62 m	1
▲	M4-7-595	Black on White	12.70	12.70	–	280
⊙	M4C-750-595-WT-BK	Black on White	19.05	–	7.62 m	1
▲	M4-11-595	Black on White	19.05	12.70	–	360
⊙	M4C-1000-595-WT-BK	Black on White	25.40	–	7.62 m	1
▲	M4-17-595	Black on White	25.40	12.70	–	360
▲	M4-49-595	Black on White	25.40	25.40	–	160
⊙	M5C-1500-595-WT-BK	Black on White	38.10	–	7.62 m	1
▲	M5-31-595	Black on White	38.10	25.40	–	250
⊙	M4C-375-595-YL-BK	Black on Yellow	9.53	–	7.62 m	1
⊙	M4C-500-595-YL-BK	Black on Yellow	12.70	–	7.62 m	1
⊙	M4C-750-595-YL-BK	Black on Yellow	19.05	–	7.62 m	1
⊙	M4C-1000-595-YL-BK	Black on Yellow	25.40	–	7.62 m	1
⊙	M5C-1500-595-YL-BK	Black on Yellow	38.10	–	7.62 m	1
⊙	M4C-500-595-WT-RD	Red on White	12.70	–	7.62 m	1
⊙	M4C-750-595-WT-RD	Red on White	19.05	–	7.62 m	1
⊙	M4C-1000-595-WT-RD	Red on White	25.40	–	7.62 m	1
⊙	M5C-1500-595-WT-RD	Red on White	38.10	–	7.62 m	1
⊙	M4C-500-595-BK-WT	White on Black	12.70	–	7.62 m	1
⊙	M4C-750-595-BK-WT	White on Black	19.05	–	7.62 m	1
⊙	M4C-1000-595-BK-WT	White on Black	25.40	–	7.62 m	1
⊙	M5C-1500-595-BK-WT	White on Black	38.10	–	7.62 m	1

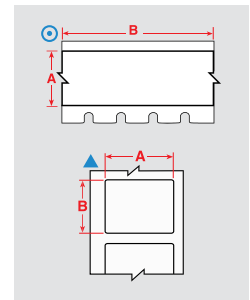

>>

General & industrial identification

Facility identification, General ID, Safety labeling and LEAN 5S



Create a colour-coded LEAN work environment with these durable labeling materials (continued)

Diagram	Order Reference	Colour	Label Width A (mm)	Label Height B (mm)	Label Length B (m)	Labels per Roll
⊙	M4C-500-595-BL-WT	White on Blue	12.70	–	7.62 m	1
⊙	M4C-750-595-BL-WT	White on Blue	19.05	–	7.62 m	1
⊙	M4C-1000-595-BL-WT	White on Blue	25.40	–	7.62 m	1
⊙	M5C-1500-595-BL-WT	White on Blue	38.10	–	7.62 m	1
⊙	M4C-500-595-GN-WT	White on Green	12.70	–	7.62 m	1
⊙	M4C-750-595-GN-WT	White on Green	19.05	–	7.62 m	1
⊙	M4C-1000-595-GN-WT	White on Green	25.40	–	7.62 m	1
⊙	M5C-1500-595-GN-WT	White on Green	38.10	–	7.62 m	1
⊙	M4C-375-595-RD-WT	White on Red	9.53	–	7.62 m	1
⊙	M4C-500-595-RD-WT	White on Red	12.70	–	7.62 m	1
⊙	M4C-750-595-RD-WT	White on Red	19.05	–	7.62 m	1
⊙	M4C-1000-595-RD-WT	White on Red	25.40	–	7.62 m	1
⊙	M5C-1500-595-RD-WT	White on Red	38.10	–	7.62 m	1
⊙	M4C-500-595-CL-WT	White on Transparent	12.70	–	6.10 m	1
⊙	M4C-750-595-CL-WT	White on Transparent	19.05	–	6.10 m	1
⊙	M4C-1000-595-CL-WT	White on Transparent	25.40	–	6.10 m	1
⊙	M5C-1500-595-CL-WT	White on Transparent	38.10	–	6.10 m	1

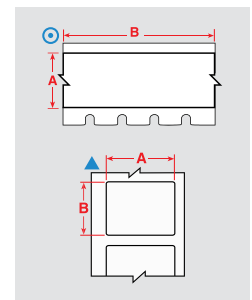

Enjoy a more premium labelling experience with optimised Brady Authentic materials



Laboratory identification

Specimen tracking identification



Vial / Tube Labels

Brady's vial and test tube labels are designed to withstand extreme laboratory solvents like Xylene, Ethanol, Alcohol and DMSO, ensuring that the specimen identification is always legible - and will not smear, fade or fall off.

Diagram	Order Reference	Material	Special Properties	Label Width A (mm)	Label Height B (mm)	Label Length B (m)	Printable Area Width PW (mm)	Labels per Roll
0.6 ml								
⊙	M4C-375-499	B-499	F N A	9.53	-	4.88	-	1
1.0 - 8.0 ml								
▲	M4-48-498	B-498	F R	25.40	19.05	-	-	180
▲	M5-125-492	B-492	F N H L	44.45	25.40	-	-	180
1.5 - 2.0 ml								
▲	M5-124-492	B-492	F N H L	12.70	41.91	-	-	180
1.5 ml								
⊙	M4C-500-499	B-499	F N A	12.70	-	4.88	-	1
2.0 - 8.0 ml								
▲	M5-131-494-BL	B-494	F N H	25.40	12.70	-	25.40	180
▲	M5-131-494-GN	B-494	F N H	25.40	12.70	-	25.40	180
▲	M5-131-494-OR	B-494	F N H	25.40	12.70	-	25.40	180
▲	M5-131-494-PK	B-494	F N H	25.40	12.70	-	25.40	180
▲	M5-131-494-RD	B-494	F N H	25.40	12.70	-	25.40	180
▲	M5-131-494-YL	B-494	F N H	25.40	12.70	-	25.40	180
▲	M5-49-494-BL	B-494	F N H	25.40	25.40	-	25.40	260
▲	M5-49-494-GN	B-494	F N H	25.40	25.40	-	25.40	260
▲	M5-49-494-OR	B-494	F N H	25.40	25.40	-	25.40	260
▲	M5-49-494-PK	B-494	F N H	25.40	25.40	-	25.40	260
▲	M5-49-494-RD	B-494	F N H	25.40	25.40	-	25.40	260
▲	M5-49-494-YL	B-494	F N H	25.40	25.40	-	25.40	260
2.0 - 50.0 ml								
⊙	M4C-750-499	B-499	F N A	19.05	-	4.88	-	1
▲	M4C-750-427	B-427	F N S	19.05	-	7.62	9.53	1
⊙	M5C-1000-499	B-499	F N A	25.40	-	4.88	-	1
15.0 ml								
▲	M5-31-7425	B-7425	F N A H	38.10	25.40	-	-	250

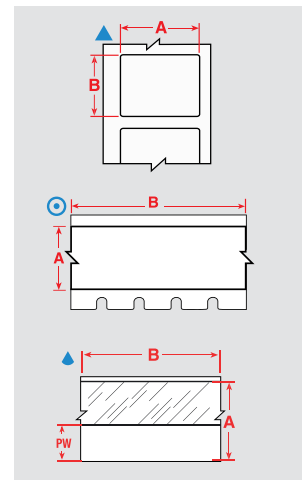

F Freezer environment
N Liquid nitrogen environment
A Autoclave environment
H Hot water bath (100°C)
S Self-laminating label
L Low-profile label (extremely thin)
R Removable

Specimen tracking identification



Vial Top Labels

Save time by using the Vial and Vial top combination labels - print your information in one go.

Diagram	Order Reference	Material	Special Properties	Label Width A (mm)	Label Height B (mm)	Diameter C (mm)	Labels per Roll
0.5 - 0.7 ml							
❖	M5-118-7425	B-7425	F N A H	25.40	9.53	9.53	240
0.5 - 1.5 ml							
✘	M4-82-499	B-499	F A	-	-	9.53	240
✘	M4-82-499-OR-BK	B-499	F A	-	-	9.53	240
✘	M4-82-499-RD-BK	B-499	F A	-	-	9.53	240
✘	M4-82-499-YL-BK	B-499	F A	-	-	9.53	240
✘	M4-82-492	B-492	F H L	-	-	9.53	240
1.0 - 2.0 ml							
❖	M5-118-499	B-499	F A	25.40	9.53	9.53	240
❖	M5-118-492	B-492	F H L	25.40	9.53	9.53	240
1.0 - 8.0 ml							
❖	M5-118-494-BL	B-494	F N H	25.40	9.53	9.53	240
❖	M5-118-494-GN	B-494	F N H	25.40	9.53	9.53	240
❖	M5-118-494-OR	B-494	F N H	25.40	9.53	9.53	240
❖	M5-118-494-PK	B-494	F N H	25.40	9.53	9.53	240
❖	M5-118-494-RD	B-494	F N H	25.40	9.53	9.53	240
❖	M5-118-494-YL	B-494	F N H	25.40	9.53	9.53	240
1.5 - 2.0 ml							
❖	M5-117-499	B-499	F A	22.86	12.70	11.18	240
❖	M5-117-492	B-492	F H L	22.86	12.70	11.18	240
❖	M5-120-499	B-499	F A	25.40	12.70	9.53	240
❖	M5-120-494-BL	B-494	F N H	25.40	12.70	9.53	240
❖	M5-120-494-GN	B-494	F N H	25.40	12.70	9.53	240
❖	M5-120-494-OR	B-494	F N H	25.40	12.70	9.53	240
❖	M5-120-494-PK	B-494	F N H	25.40	12.70	9.53	240
❖	M5-120-494-RD	B-494	F N H	25.40	12.70	9.53	240
❖	M5-120-494-YL	B-494	F N H	25.40	12.70	9.53	240
❖	M5-120-492	B-492	F H L	25.40	12.70	9.53	240
▽	M5-95-492	B-492	F H L	41.28	15.24	9.53	200
✘	M4-83-499	B-499	F A	-	-	12.70	240
✘	M4-83-499-OR-BK	B-499	F A	-	-	12.70	240
✘	M4-83-499-RD-BK	B-499	F A	-	-	12.70	240
✘	M4-83-499-YL-BK	B-499	F A	-	-	12.70	240
✘	M4-83-492	B-492	F H L	-	-	12.70	240

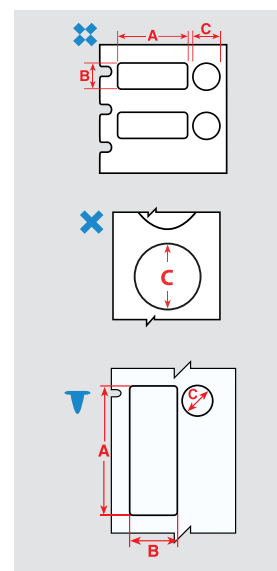



Laboratory identification

Specimen tracking identification



Conical / large tube labels

Brady offers several sample identification labels which are perfect to identify conicals. They are easy to handle, have great flexibility and easily wrap around curved sample containers. Your sample identification label will remain attached and legible, even when the sample is stored in a freezer, in liquid nitrogen or heated in an autoclave.

Diagram	Order Reference	Material	Special Properties	Label Width A (mm)	Label Height B (mm)	Label Length B (m)	Diameter C (mm)	Printable Area Width PW (mm)	Printable Area Height PH (mm)	Labels per Roll
1.0 - 8.0 ml										
▲	M5-125-492	B-492	F N H L	44.45	25.40	–	–	–	–	180
1.0 - 15.0 ml										
▲	M5-156-492	B-492	F N H L	22.86	25.40	–	–	–	–	180
1.5 - 2.0 ml										
▲	M5-124-492	B-492	F N H L	12.70	41.91	–	–	–	–	180
1.5 ml										
○	M4C-500-499	B-499	F N A	12.70	–	4.88	–	–	–	1
2.0 - 50.0 ml										
○	M4C-750-499	B-499	F N A	19.05	–	4.88	–	–	–	1
▲	M4C-750-427	B-427	F N S	19.05	–	7.62	–	9.53	–	1
○	M5C-1000-499	B-499	F N A	25.40	–	4.88	–	–	–	1
▲	M5C-1000-427	B-427	F N S	25.40	–	7.62	–	9.53	–	1
○	M5C-1000-461	B-461	F N A H S L	25.40	–	7.62	–	–	–	1
4.0 - 50.0 ml										
▲	M5C-1250-427	B-427	F N S	31.75	–	7.62	–	12.70	–	1
○	M5C-1250-461	B-461	F N A H S L	31.75	–	7.62	–	–	–	1
5.0 - 50.0 ml										
▲	M5C-1500-427	B-427	F N S	38.10	–	7.62	–	12.70	–	1
12.0 - 14.0 ml										
▷	M5-119-461	B-461	F N A H S L	95.25	38.10	–	–	31.75	38.10	80
12.0 - 24.0 ml										
▲	M5-78-492	B-492	F N H L	25.40	48.26	–	–	–	–	100
▲	M5-132-499	B-499	F N A	38.10	31.75	–	–	–	–	160
14.0 - 15.0 ml										
▲	M5-113-490	B-490	F N H L	38.10	55.88	–	–	–	–	140
▷	M5-116-427	B-427	F N S	38.10	63.50	–	–	38.10	19.05	80
▷	M5-129-461	B-461	F N A H S L	57.15	38.10	–	–	31.75	38.10	140
50.0 ml										
▷	M4-90-427	B-427	F N S	19.05	38.10	–	–	19.05	12.70	180
▷	M4-91-427	B-427	F N S	25.40	38.10	–	–	25.40	12.70	180
▲	M5-114-490	B-490	F N H L	38.10	95.25	–	–	–	–	80
▲	M4-128-499	B-499	F N A	48.26	25.40	–	–	–	–	100

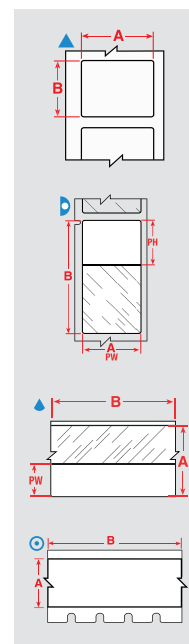

F Freezer environment **N** Liquid nitrogen environment **A** Autoclave environment **H** Hot water bath (100°C) **S** Self-laminating label **L** Low-profile label (extremely thin) **R** Removable

Laboratory identification

Specimen process marking



Centrifuge / microcentrifuge labels

Brady offers a wide range of Centrifuge, Eppendorf and PCR Labels.

When applying a self-laminating label, we recommend you avoid touching the adhesive side of the label when wrapping it around a vial or tube, to ensure maximum adhesion.

Diagram	Order Reference	Material	Special Properties	Label Width A (mm)	Label Height B (mm)	Label Length B (m)	Diameter C (mm)	Printable Area Width PW (mm)	Printable Area Height PH (mm)	Labels per Roll
0.5 - 0.7 ml										
▲	M4-11-499	B-499	FNA	19.05	12.70	–	–	–	–	220
▷	M5-123-461	B-461	FNAHSL	28.58	9.53	–	–	19.05	9.53	360
▷	M5-122-461	B-461	FNAHSL	28.58	12.70	–	–	19.05	12.70	360
▲	M5-112-490	B-490	FNHL	31.75	9.53	–	–	–	–	360
▲	M5-112-492	B-492	FNHL	31.75	9.53	–	–	–	–	360
▷	M4-72-461	B-461	FNAHSL	44.45	12.70	–	–	19.05	12.70	180
0.5 - 1.5 ml										
✕	M4-82-492	B-492	FHL	–	–	–	9.53	–	–	240
✕	M4-82-499-RD-BK	B-499	FA	–	–	–	9.53	–	–	240
0.6 ml										
⊙	M4C-375-499	B-499	FNA	9.53	–	4.88	–	–	–	1
▲	M4-130-492	B-492	FNHL	20.96	9.53	–	–	–	–	220
▲	M4-130-499	B-499	FNA	20.96	9.53	–	–	–	–	220
▲	M5-84-499	B-499	FNA	22.86	12.70	–	–	–	–	200
▲	M5-155-492	B-492	FNHL	31.75	6.35	–	–	–	–	180
1.0 - 2.0 ml										
⊘	M5-118-492	B-492	FHL	25.40	9.53	–	9.53	–	–	240
⊘	M5-118-499	B-499	FA	25.40	9.53	–	9.53	–	–	240
1.0 - 8.0 ml										
▲	M4-131-492	B-492	FNHL	25.40	12.70	–	–	–	–	180
▲	M4-131-499	B-499	FNA	25.40	12.70	–	–	–	–	180
▷	M4-126-461	B-461	FNAHSL	45.72	15.24	–	–	25.40	15.24	180
▲	M4-126-490	B-490	FNHL	45.72	15.24	–	–	–	–	180
▷	M4-74-461	B-461	FNAHSL	55.88	12.70	–	–	19.05	12.70	140
▷	M4-86-461	B-461	FNAHSL	66.68	15.24	–	–	25.40	15.24	120

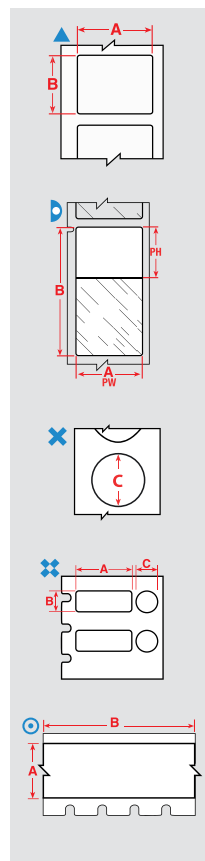

>>



Laboratory identification

Specimen process marking



Centrifuge / microcentrifuge labels (continued)

Diagram	Order Reference	Material	Special Properties	Label Width A (mm)	Label Height B (mm)	Label Length B (m)	Diameter C (mm)	Printable Area Width PW (mm)	Printable Area Height PH (mm)	Labels per Roll
1.5 - 2.0 ml										
▲	M4-124-490	B-490	F N H L	12.70	41.91	–	–	–	–	180
▲	M5-124-492	B-492	F N H L	12.70	41.91	–	–	–	–	180
⌘	M5-117-492	B-492	F H L	22.86	12.70	–	11.18	–	–	240
⌘	M5-117-499	B-499	F A	22.86	12.70	–	11.18	–	–	240
⌘	M5-120-492	B-492	F H L	25.40	12.70	–	9.53	–	–	240
⌘	M5-120-499	B-499	F A	25.40	12.70	–	9.53	–	–	240
▷	M4-124-461	B-461	F N A H S L	41.91	12.70	–	–	19.05	12.70	180
×	M4-83-492	B-492	F H L	–	–	–	12.70	–	–	240
×	M4-83-499-OR-BK	B-499	F A	–	–	–	12.70	–	–	240
×	M4-83-499-RD-BK	B-499	F A	–	–	–	12.70	–	–	240
1.5 ml										
⊙	M4C-500-499	B-499	F N A	12.70	–	4.88	–	–	–	1
⊙	M4C-500-461	B-461	F N A H S L	12.70	–	7.62	–	–	–	1
⊙	M4C-500-492	B-492	F N H L	12.70	–	7.62	–	–	–	1
2.0 - 50.0 ml										
⊙	M4C-750-499	B-499	F N A	19.05	–	4.88	–	–	–	1
▲	M4C-750-427	B-427	F N S	19.05	–	7.62	–	9.53	–	1
⊙	M5C-1000-499	B-499	F N A	25.40	–	4.88	–	–	–	1

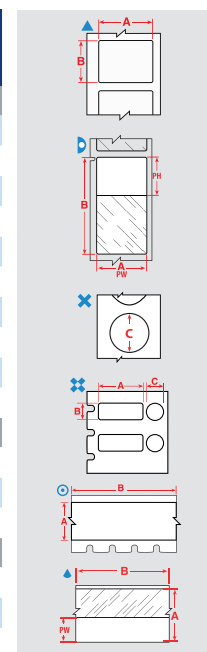

Straw and rod labels

Brady offers a range of labels designed to fit the small surface area of straws and rods and will withstand long-term storage.

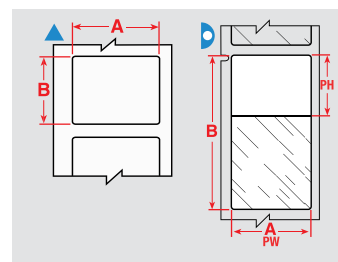

Diagram	Order Reference	Material	Special Properties	Label Width A (mm)	Label Height B (mm)	Printable Area Width PW (mm)	Printable Area Height PH (mm)	Labels per Roll
0.25 ml								
▷	M4-49-427	B-427	F N S	25.40	25.40	25.40	9.53	260
▷	M5-133-427	B-427	F N S	44.45	25.40	38.10	9.53	140
0.50 ml								
▷	M4-51-427	B-427	F N S	25.40	63.50	25.40	19.05	110
▷	M5-134-427	B-427	F N S	44.45	38.10	44.45	12.70	140
Straw Rod								
▲	M4-135-427-AW	B-427	F N	6.35	27.94	–	–	240

F Freezer environment **N** Liquid nitrogen environment **A** Autoclave environment **H** Hot water bath (100°C) **S** Self-laminating label **L** Low-profile label (extremely thin) **R** Removable

Laboratory identification

Specimen process marking

Slide labels

Brady offers labels specifically designed to identify slides and to resist exposure to harsh chemicals during the slide staining process. They perform well in the hematoxylin and eosin slide staining process and offer superior chemical resistance also useful in other laboratory contexts.

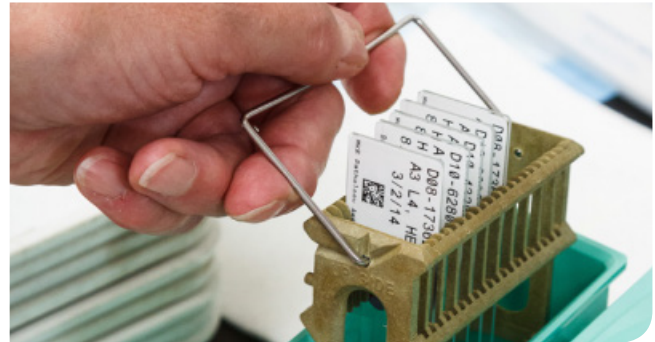
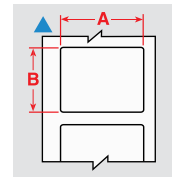

Diagram	Order Reference	Material	Special Properties	Label Width A (mm)	Label Height B (mm)	Labels per Roll
▲	M5-194-481	B-481	F H	22.86	19.05	320
▲	M5-97-488	B-488	F A	22.86	22.86	280
▲	M5-97-481	B-481	F H	22.86	22.86	280
▲	M5-195-481	B-481	F H	25.40	9.53	320
▲	M5-31-7425	B-7425	F N A H	38.10	25.40	250
▲	M4-81-488	B-488	F A	48.26	6.35	160



Tissue Cassette Labels

Tissue cassettes are often re-identified when labs collect samples from various biorepositories. Typically, each laboratory has its own unique way of identifying samples, which creates a need to re-identify samples in a common way.

Brady B-498 post-process labels offer customers the optimal way to organise these specimens and conduct further studies. These labels can be applied directly onto the cassettes, on pure paraffin wax and on top of another label or identifier.



Diagram	Order Reference	Material	Special Properties	Label Width A (mm)	Label Height B (mm)	Labels per Roll
▲	M4-11-498	B-498	F R	19.05	12.70	220

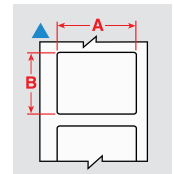

Enjoy a more premium labelling experience with optimised Brady Authentic materials



Laboratory identification

Specimen storage identification



Cryo tubes & vials

Brady offers a range of labels designed specifically to identify laboratory samples for cryo storage. These labels can be applied to room temperature or to already frozen samples, albeit with a small overlap. The label will remain legible and will stick to the sample container during processing, even when exposed to extreme heat or chemicals like DMSO, Xylene and Ethanol, ensuring secure sample identification in the most challenging laboratory conditions.

Diagram	Order Reference	Material	Special Properties	Label Width A (mm)	Label Height B (mm)	Label Length B (m)	Printable Area Width PW (mm)	Printable Area Height PH (mm)	Labels per Roll
0.5 - 0.7 ml									
▲	M4-11-499	B-499	FNA	19.05	12.70	-	-	-	220
▷	M5-123-461	B-461	FNAHSL	28.58	9.53	-	19.05	9.53	360
▷	M5-122-461	B-461	FNAHSL	28.58	12.70	-	19.05	12.70	360
▲	M5-112-490	B-490	FNHL	31.75	9.53	-	-	-	360
▷	M4-72-461	B-461	FNAHSL	44.45	12.70	-	19.05	12.70	180
0.6 ml									
◎	M4C-375-499	B-499	FNA	9.53	-	4.88	-	-	1
◎	M4C-375-461	B-461	FNAHSL	9.53	-	7.62	-	-	1
▲	M4-130-499	B-499	FNA	20.96	9.53	-	-	-	220
▲	M4-130-492	B-492	FNHL	20.96	9.53	-	-	-	220
▲	M5-84-499	B-499	FNA	22.86	12.70	-	-	-	200
1.0 - 8.0 ml									
▲	M4-131-499	B-499	FNA	25.40	12.70	-	-	-	180
▲	M4-131-492	B-492	FNHL	25.40	12.70	-	-	-	180
▷	M5-125-461	B-461	FNAHSL	44.45	25.40	-	25.40	25.40	180
▲	M5-125-490	B-490	FNHL	44.45	25.40	-	-	-	180
▷	M4-126-461	B-461	FNAHSL	45.72	15.24	-	25.40	15.24	180
▲	M4-126-490	B-490	FNHL	45.72	15.24	-	-	-	180
▷	M4-74-461	B-461	FNAHSL	55.88	12.70	-	19.05	12.70	140
▷	M4-86-461	B-461	FNAHSL	66.68	15.24	-	25.40	15.24	120
▷	M5-75-461	B-461	FNAHSL	66.68	25.40	-	25.40	25.40	120
1.0 - 15.0 ml									
▲	M5-156-492	B-492	FNHL	22.86	25.40	-	-	-	180
1.5 ml									
◎	M4C-500-499	B-499	FNA	12.70	-	4.88	-	-	1
◎	M4C-500-461	B-461	FNAHSL	12.70	-	7.62	-	-	1
2.0 - 50.0 ml									
◎	M4C-750-499	B-499	FNA	19.05	-	4.88	-	-	1
◎	M5C-1000-499	B-499	FNA	25.40	-	4.88	-	-	1
◎	M5C-1000-461	B-461	FNAHSL	25.40	-	7.62	-	-	1
4.0 - 50.0 ml									
◎	M5C-1250-461	B-461	FNAHSL	31.75	-	7.62	-	-	1
12.0 - 14.0 ml									
▷	M5-119-461	B-461	FNAHSL	95.25	38.10	-	31.75	38.10	80
12.0 - 24.0 ml									
▲	M5-78-492	B-492	FNHL	25.40	48.26	-	-	-	100
▲	M5-132-499	B-499	FNA	38.10	31.75	-	-	-	160

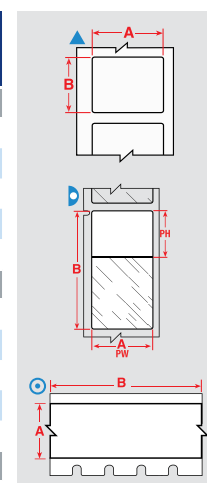

F Freezer environment **N** Liquid nitrogen environment **A** Autoclave environment **H** Hot water bath (100°C) **S** Self-laminating label **L** Low-profile label (extremely thin) **R** Removable

Laboratory identification

Specimen storage identification

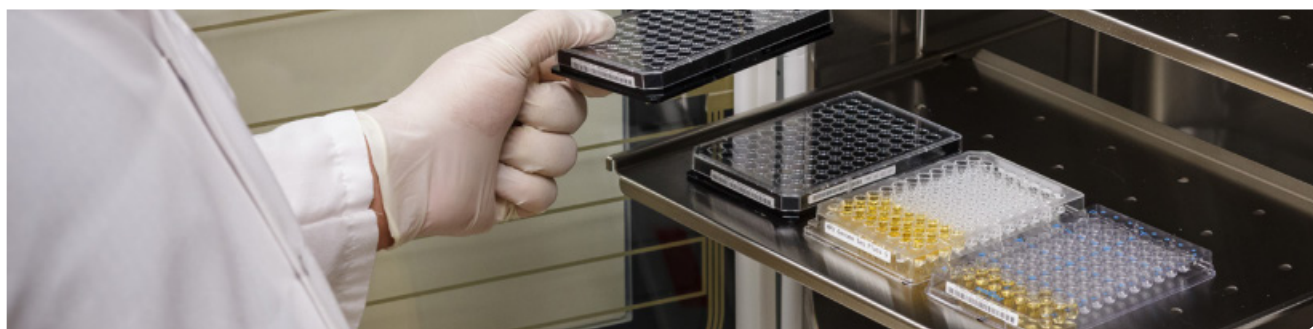

Well plate labels

When total tracking of all sample collections is required then Brady has a solution for Well plate identification. Our well plate labels guarantee crystal clear text and barcoding for most lab environments.

Diagram	Order Reference	Material	Special Properties	Label Width A (mm)	Label Height B (mm)	Label Length B (m)	Labels per Roll
⊙	M4C-375-499	B-499	FNA	9.53	–	4.88	1
⊙	M4C-375-595-RD-WT	B-595	F	9.53	–	7.62	1
⊙	M4C-375-595-WT-BK	B-595	F	9.53	–	7.62	1
⊙	M4C-375-595-YL-BK	B-595	F	9.53	–	7.62	1
⊙	M4C-500-499	B-499	FNA	12.70	–	4.88	1
⊙	M4C-500-595-CL-BK	B-595	F	12.70	–	6.10	1
⊙	M4C-500-595-CL-WT	B-595	F	12.70	–	6.10	1
⊙	M4C-500-595-BK-WT	B-595	F	12.70	–	7.62	1
⊙	M4C-500-595-BL-WT	B-595	F	12.70	–	7.62	1
⊙	M4C-500-595-GN-WT	B-595	F	12.70	–	7.62	1
⊙	M4C-500-595-OR-BK	B-595	F	12.70	–	7.62	1
⊙	M4C-500-595-RD-WT	B-595	F	12.70	–	7.62	1
⊙	M4C-500-595-WT-BK	B-595	F	12.70	–	7.62	1
⊙	M4C-500-595-WT-RD	B-595	F	12.70	–	7.62	1
⊙	M4C-500-595-YL-BK	B-595	F	12.70	–	7.62	1
⊙	M4C-750-499	B-499	FNA	19.05	–	4.88	1
⊙	M4C-750-595-CL-BK	B-595	F	19.05	–	6.10	1
⊙	M4C-750-595-CL-WT	B-595	F	19.05	–	6.10	1
⊙	M4C-750-595-BK-WT	B-595	F	19.05	–	7.62	1
⊙	M4C-750-595-BL-WT	B-595	F	19.05	–	7.62	1
⊙	M4C-750-595-GN-WT	B-595	F	19.05	–	7.62	1
⊙	M4C-750-595-OR-BK	B-595	F	19.05	–	7.62	1
⊙	M4C-750-595-RD-WT	B-595	F	19.05	–	7.62	1
⊙	M4C-750-595-WT-BK	B-595	F	19.05	–	7.62	1
⊙	M4C-750-595-WT-RD	B-595	F	19.05	–	7.62	1
⊙	M4C-750-595-YL-BK	B-595	F	19.05	–	7.62	1
▲	M5-17-432-CL-BK	B-432	F A	25.40	12.70	–	280
⊙	M5C-1000-499	B-499	FNA	25.40	–	4.88	1
⊙	M4C-1000-595-CL-BK	B-595	F	25.40	–	6.10	1
⊙	M4C-1000-595-CL-WT	B-595	F	25.40	–	6.10	1
⊙	M4C-1000-595-BK-WT	B-595	F	25.40	–	7.62	1
⊙	M4C-1000-595-BL-WT	B-595	F	25.40	–	7.62	1
⊙	M4C-1000-595-GN-WT	B-595	F	25.40	–	7.62	1
⊙	M4C-1000-595-OR-BK	B-595	F	25.40	–	7.62	1
⊙	M4C-1000-595-RD-WT	B-595	F	25.40	–	7.62	1
⊙	M4C-1000-595-WT-BK	B-595	F	25.40	–	7.62	1
⊙	M4C-1000-595-WT-RD	B-595	F	25.40	–	7.62	1
⊙	M4C-1000-595-YL-BK	B-595	F	25.40	–	7.62	1
▲	M4-81-488	B-488	F A	48.26	6.35	–	160

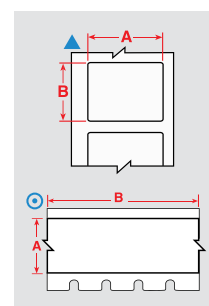

F Freezer environment	N Liquid nitrogen environment	A Autoclave environment	H Hot water bath (100°C)	S Self-laminating label	L Low-profile label (extremely thin)	R Removable
------------------------------	--------------------------------------	--------------------------------	---------------------------------	--------------------------------	---	--------------------



Laboratory identification

Lean lab identification



Bottles / flasks & dishes

Brady's labels for bottles, flasks and dishes are easy to handle and flexible. This enables the labels to be placed on curved containers and remain attached and legible, even after being subjected to freezing, liquid nitrogen and heat.

Diagram	Order Reference	Material	Special Properties	Label Width A (mm)	Label Height B (mm)	Label Length B (m)	Printable Area Width PW (mm)	Printable Area Height PH (mm)	Labels per Roll
⊙	M4C-375-499	B-499	F N A	9.53	—	4.88	—	—	1
⊙	M4C-500-499	B-499	F N A	12.70	—	4.88	—	—	1
▷	M4-90-427	B-427	F N S	19.05	38.10	—	19.05	12.70	180
⊙	M4C-750-499	B-499	F N A	19.05	—	4.88	—	—	1
▲	M4-130-499	B-499	F N A	20.96	9.53	—	—	—	220
▲	M4-131-499	B-499	F N A	25.40	12.70	—	—	—	180
▲	M4-131-498	B-498	F	R 25.40	12.70	—	—	—	180
▲	M5-103-498	B-498	F	R 25.40	31.75	—	—	—	160
▷	M4-91-427	B-427	F N S	25.40	38.10	—	25.40	12.70	180
⊙	M5C-1000-499	B-499	F N A	25.40	—	4.88	—	—	1
▲	M5-132-499	B-499	F N A	38.10	31.75	—	—	—	160
▲	M4-128-498	B-498	F	R 48.26	25.40	—	—	—	100

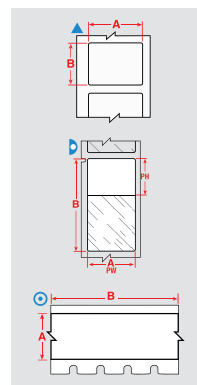

Water dissolvable labels

B-403 water dissolvable paper label dissolves completely within 30 seconds exposure to warm water without damaging the surface or leaving sticky residue, making it ideal to label items that need new identification after every use.

Diagram	Order Reference	Material	Special Properties	Label Width A (mm)	Label Length B (m)	Labels per Roll
⊙	M4C-750-403	B-403	R	19.05	7.62	1
⊙	M5C-1500-403	B-403	R	38.10	7.62	1

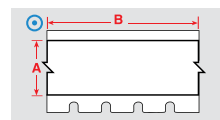

- F** Freezer environment
- N** Liquid nitrogen environment
- A** Autoclave environment
- H** Hot water bath (100°C)
- S** Self-laminating label
- L** Low-profile label (extremely thin)
- R** Removable

Laboratory identification

Lean lab identification



Bottle Tamper Seal Labels

Brady's bottle seal identification provides tracking information with the added feature of security. These labelling materials are designed to fracture easily in order to show signs of sample tampering and to prevent one-piece label removal.

Diagram	Order Reference	Material	Special Properties	Label Width A (mm)	Label Height B (mm)	Labels per Roll
▲	M5-17-351	B-351	F	25.40	12.70	360
▲	M5-20-351	B-351	F	25.40	50.80	160

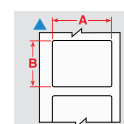

General Lab ID

Just like a durable sample label lets you know which sample you are holding, a cabinet or drawer label can inform you of the cabinet's content. With proper identification, time spent looking for the right sample or tool can be invested in what really matters. Brady offers a range of materials suitable for identifying drawers, cabinets, shelves, storage units and laboratory equipment.

Diagram	Order Reference	Material	Special Properties	Label Width A (mm)	Label Height B (mm)	Label Length B (m)	Labels per Roll
⊙	M4C-375-499	B-499	F N A	9.53	—	4.88	1
⊙	M4C-375-595-WT-BK	B-595	F	9.53	—	7.62	1
⊙	M4C-375-595-YL-BK	B-595	F	9.53	—	7.62	1
▲	M4-7-595	B-595	F	12.70	12.70	—	1
▲	M4-11-595	B-595	F	12.70	19.05	—	1
⊙	M4C-500-499	B-499	F N A	12.70	—	4.88	1
⊙	M4C-500-595-CL-BK	B-595	F	12.70	—	6.10	1
⊙	M4C-500-595-CL-WT	B-595	F	12.70	—	6.10	1
⊙	M4C-500-595-BK-WT	B-595	F	12.70	—	7.62	1
⊙	M4C-500-595-BL-WT	B-595	F	12.70	—	7.62	1

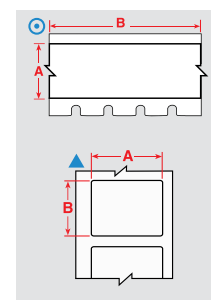

>>

F Freezer environment	N Liquid nitrogen environment	A Autoclave environment	H Hot water bath (100°C)	S Self-laminating label	L Low-profile label (extremely thin)	R Removable
------------------------------	--------------------------------------	--------------------------------	---------------------------------	--------------------------------	---	--------------------



Laboratory identification

Lean lab identification

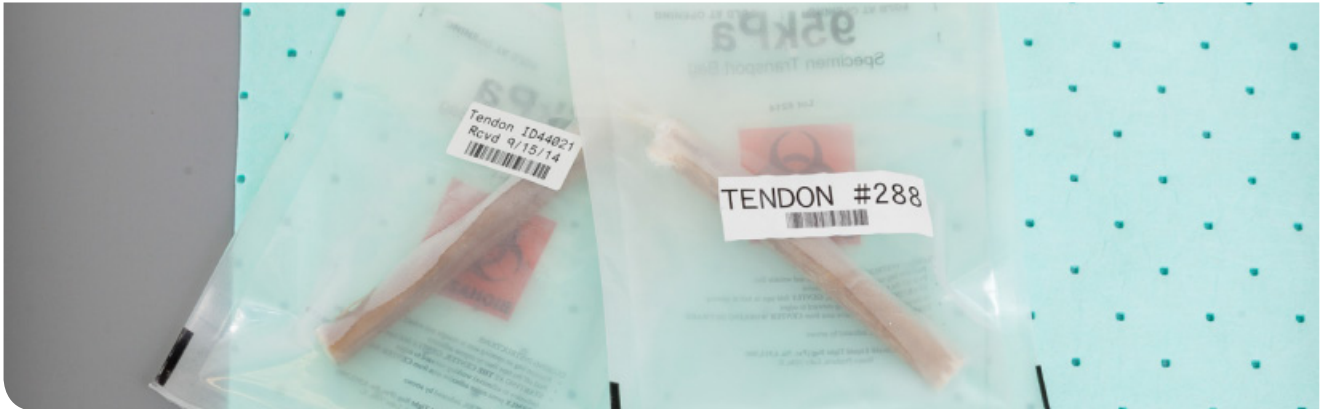

General Lab ID (continued)

Diagram	Order Reference	Material	Special Properties	Label Width A (mm)	Label Height B (mm)	Label Length B (m)	Labels per Roll
○	M4C-500-595-GN-WT	B-595	F	12.70	—	7.62	1
○	M4C-500-595-OR-BK	B-595	F	12.70	—	7.62	1
○	M4C-500-595-RD-WT	B-595	F	12.70	—	7.62	1
○	M4C-500-595-WT-BK	B-595	F	12.70	—	7.62	1
○	M4C-500-595-WT-RD	B-595	F	12.70	—	7.62	1
○	M4C-500-595-YL-BK	B-595	F	12.70	—	7.62	1
○	M4C-750-499	B-499	F N A	19.05	—	4.88	1
○	M4C-750-595-CL-BK	B-595	F	19.05	—	6.10	1
○	M4C-750-595-CL-WT	B-595	F	19.05	—	6.10	1
○	M4C-750-595-BK-WT	B-595	F	19.05	—	7.62	1
○	M4C-750-595-BL-WT	B-595	F	19.05	—	7.62	1
○	M4C-750-595-GN-WT	B-595	F	19.05	—	7.62	1
○	M4C-750-595-OR-BK	B-595	F	19.05	—	7.62	1
○	M4C-750-595-RD-WT	B-595	F	19.05	—	7.62	1
○	M4C-750-595-WT-BK	B-595	F	19.05	—	7.62	1
○	M4C-750-595-WT-RD	B-595	F	19.05	—	7.62	1
○	M4C-750-595-YL-BK	B-595	F	19.05	—	7.62	1
▲	M4-130-499	B-499	F N A	20.96	9.53	—	220
▲	M4-131-499	B-499	F N A	25.40	12.70	—	180
▲	M4-131-498	B-498	F R	25.40	12.70	—	180
▲	M4-17-595	B-595	F	25.40	12.70	—	1
▲	M5-17-432-CL-BK	B-432	F A	25.40	12.70	—	280
▲	M4-49-595	B-595	F	25.40	25.40	—	1
▲	M5-103-498	B-498	F R	25.40	31.75	—	160
▲	M5-78-432-CL-BK	B-432	F A	25.40	48.26	—	100
○	M5C-1000-499	B-499	F N A	25.40	—	4.88	1
○	M4C-1000-595-CL-BK	B-595	F	25.40	—	6.10	1
○	M4C-1000-595-CL-WT	B-595	F	25.40	—	6.10	1
○	M4C-1000-595-BK-WT	B-595	F	25.40	—	7.62	1
○	M4C-1000-595-BL-WT	B-595	F	25.40	—	7.62	1
○	M4C-1000-595-GN-WT	B-595	F	25.40	—	7.62	1
○	M4C-1000-595-OR-BK	B-595	F	25.40	—	7.62	1
○	M4C-1000-595-RD-WT	B-595	F	25.40	—	7.62	1
○	M4C-1000-595-WT-BK	B-595	F	25.40	—	7.62	1
○	M4C-1000-595-WT-RD	B-595	F	25.40	—	7.62	1
○	M4C-1000-595-YL-BK	B-595	F	25.40	—	7.62	1
▲	M5-31-595	B-595	F	38.10	25.40	—	1
▲	M5-132-499	B-499	F N A	38.10	31.75	—	160
▲	M4-128-498	B-498	F R	48.26	25.40	—	100

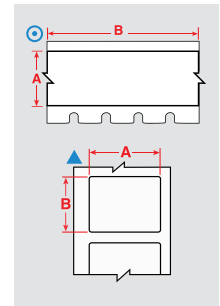

F Freezer environment
N Liquid nitrogen environment
A Autoclave environment
H Hot water bath (100°C)
S Self-laminating label
L Low-profile label (extremely thin)
R Removable

Material index

This section provides a quick reference to Brady materials listed throughout this brochure, including applications and regulatory compliance where applicable. For more detailed material attribute and performance information, please refer to the material's Technical Data Sheet, listed at www.bradyeurope.com/tds

Material	Finish	Temp (°C) (Tested for 30 days)	Additional Features	Approval/Compliance
FreezerBondz™ Polyester				
B-490	Matt	-196 °C 130 °C	Can be applied to frozen surfaces including glass and polypropylene stored in liquid nitrogen, except for Vial Tops. Material must slightly overlap itself.	
B-492	Matt	-196 °C 110 °C	Ultra thin; can label frosted/frozen (with overlap) or room temperature labels and lasts in liquid nitrogen and hot water baths	
Heat-shrink Polyolefin				
B-342	Matt	-55 °C 130.6 °C	3:1 ratio heat shrinkable wire marking sleeve that fits snugly around wires for identification and protection. Fade-resistant and flame retardant. Also available in yellow, black, blue, brown, green, gray, orange, pink, red, violet.	UL Recognised to UL224, SAE-AMS-DTL-23053/5 C (Class 1), SAE AS-81531
B-7641	Matt	-55 °C 105 °C	2:1 ratio heat shrinkable, zero halogen wire marking sleeves. The wire marking sleeves offer outstanding fire safety properties and minimal smoke emission. Also available in yellow.	BS-6853 (1999) Vehicle Category 1A; EN-45545-2, requirement 24, Vehicle Category HL3, Zero Halogen
Metallised Polyester				
B-428	Matt	-70 °C 120 °C	Thermal transfer printable metallised polyester with matt finish. Withstands solvents and variable temperatures. Excellent for serial and rating plate applications with name-plate quality and a metal-looking finish.	UL Recognised, CSA Accepted, AGA Approved, Halogen Free (DIN VDE 0472/part 815)
Nylon Cloth				
B-499	Matt	-40 °C 90 °C	Nylon cloth material with matt finish. The adhesive allows labelling in environments with heat, cold, oil and dirt. Also available in orange, red and yellow.	UL Recognised, CSA Accepted, Halogen Free (DIN VDE 0472/part 815) Approvals are for White material only
Paper				
B-403	Matt	-70 °C 100 °C	White dissolvable paper. Dissolves completely in water leaving no adhesive residue, ideal for temporary labelling applications	
Polyester				
B-414	Matt	-40 °C 50 °C	Get a grip on your wire and cable identification – Brady and VELCRO® Brand have partnered to bring you BradyGrip™ Print-on Hook Material, an exclusive print-and-place material that can be easily applied, repositioned or removed.	
B-422	Gloss	-40 °C 100 °C	White material stock with glossy finish and 2 mils of adhesive for rough surface applications, including low surface energy plastics. Designed to withstand solvent exposure. UL rated for surfaces commonly used in solar panel manufacturing. Also used for component identification, barcoding, asset and inventory tracking.	UL Recognised, CSA Accepted
B-432	Gloss	-40 °C 100 °C	Translucent, high performance polyester material with a glossy finish. Thermal transfer printable. Very similar to B-430, but has a thicker layer of acrylic adhesive for better adherence to rough surface applications.	UL Recognised, CSA Accepted
B-482	Matt		The B-482 label material, combined with Brady's R6400 ribbon, provides the durability and print quality that histology and anatomic pathology labs need for accurate, identifiable specimen labelling. Paraffin and solvent resistant.	
B-483A	Gloss	-40 °C 120 °C	White polyester thermal transfer printable material with glossy finish and aggressive adhesive specifically designed for powder coated surfaces.	UL Recognised, CSA Accepted
B-488	Matt	-40 °C 145 °C	White polyester thermal transfer printable material, similar to B-423, but with matt finish. Widely used for component identification, barcoding, asset and inventory tracking.	
B-494	Gloss	-196 °C 70 °C	Our B-494 polyester label is a reliable sample identification and traceability solution. The label will stay attached and remain legible, even when exposed to chemicals or stored in liquid nitrogen. Thanks to subsurface printing, the label's colour code will not fade, smear or smudge and will continue to offer fast sample recognition long after it was printed.	
Polyethylene				
B-109	Matt	-40 °C 49 °C	White polyethylene tag material with matt finish. Excellent multi-purpose tag for identifying multiconductor cables, inventory, safety warning repair and work-in-processing manufacturing. Good weatherability, humidity resistance and legibility after solvent exposure.	
B-145	Matt	-40 °C 100 °C	This multipurpose material can be used for a variety of tag applications including identification of multiconductor cables, equipment, safety warning repair and workinprogress.	

>>

Material index

Material	Finish	Temp (°C) (Tested for 30 days)	Additional Features	Approval/Compliance
Polypropylene				
B-412	Matt	-40 °C 100 °C	White polypropylene tag material with matt finish. Offers high print legibility and high tensile strength.	
B-425A	Matt	-70 °C 80 °C	White polypropylene material stock with matt finish for thermal transfer printing or write-on applications. Excellent solvent resistance and print performance; not recommended for long-term outdoor use.	UL Recognised, CSA Accepted, Halogen Free (DIN VDE 0472/part 815)
B-7425	Matt	-80 °C 70 °C	White Polypropylene material. Ideal for laboratory identification such as vials, centrifuge tubes and test tubes. For freezer or liquid nitrogen applications, B-7425 must be applied prior to being frozen.	
Reflective Tape				
B-584	Gloss	-40 °C 70 °C	Suitable for outdoor use. Also available in silver and yellow.	
Self-laminating Polyester				
B-461	Matt	-196 °C 110 °C	Permanent adhesive; suitable for liquid nitrogen application if material is wrapped around itself, as in self-lamination; write-on capabilities. Temperature range increases to 121°C when used in autoclave process	
Self-laminating Vinyl				
B-417	Matt	-40 °C 70 °C	Keep your wire identification secure with this self-laminating marker with extra-strong adhesive. The extra-strong adhesive makes these markers ideal for small-diameter wires. Features a white printable area and a clear tail that wraps around the marker.	UL Recognised to UL969 Labelling and Marking Standard when printed with the Brady Series R4300 and R7950 ribbons. See UL files MH62024 for specific details. Brady customers should specify at purchase if they require UL Recognised B-417 labels. Brady sells both UL Recognised B-417 labels and non-approved labels depending on customer requirements
B-427	Matt	-40 °C 60 °C	Thermal transfer printable, self-laminating material. These labels have a printable area with a clear "tail" that wraps around the marker. The "tail" serves as overlamine to protect the print. Superior resistance to abrasion, solvents, water, oil and dirt. Also available in grey, brown, green, yellow, blue, red, purple, orange	UL Recognised to UL969 Labelling and Marking Standard when printed with the Brady Series R4300 and R6200 ribbons. See UL files MH17154 for specific details. Brady customers should specify at purchase if they require UL Recognised B-427 labels. Brady sells both UL Recognised B-427 labels and non-approved labels depending on customer requirements.
StainerBondz™ Polyester				
B-481	Matt	-80 °C 130 °C	White polyester will remain resistant when exposed to xylene and other chemicals that are commonly used in the slide staining process	
Tamper-resistant Vinyl				
B-351	Matt	-40 °C 80 °C	White vinyl material with matt finish. Tamper evident material fractures to show signs of product tampering and prevent one-piece removal.	
Vinyl				
B-595	Gloss	-40 °C 82 °C	Durable, low-shrink vinyl with our most aggressive adhesive. Conforms to irregular, curved, rough and highly textured surfaces (painted cinder blocks, uneven wood, textured plastics, paper-jacketed pipes, powder-coated surfaces). Adheres to "difficult" low-surface energy items (PVC piping, blow-moulded equipment cases, ABS plastics, recycled plastics). Available in a wide range of colours.	BS 5609:1986 Section 2 and section 3
Vinyl Cloth				
B-498	Semi-gloss	-40 °C 80 °C	White vinyl cloth label material with glossy finish. The adhesive and cloth backing give excellent holding power, while being repositionable and removing cleanly.	UL Recognised



Enjoy a more premium labelling experience with optimised Brady Authentic materials



Software solutions

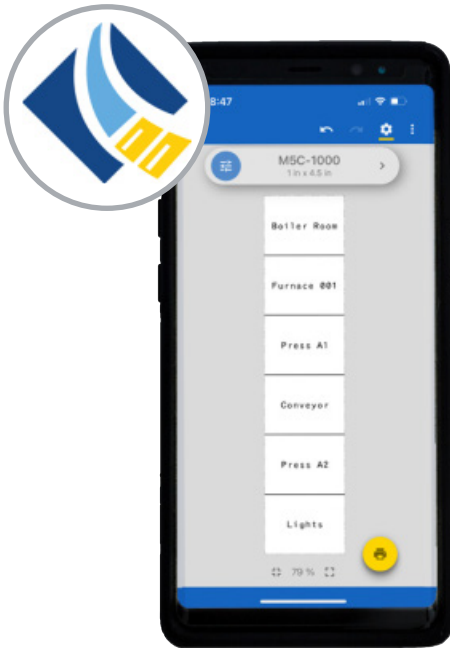

Express Labels App

Your one-stop shop for mobile printing

Brady's Express Labels App makes mobile printing convenient and simple. This intuitively designed software integrates touchscreen technology for fast and easy label creation, including label resizing using touch and a native keyboard for more natural typing. To make label creation even more convenient, the app features auto-save capabilities, tools to help you easily enter data onto your label, and easy-to-use editing tools to keep labeling projects moving smoothly.

With our Express Labels app installed, you can easily design complex labels with 1D and 2D codes and barcodes, serialise, use an extensive image library, include text, a time stamp and even data from the cloud. The Express Labels app offers the most comprehensive label design capabilities available for any smartphone and includes design wizards to quickly create specific identification labels.

▶ **Get the free app from Apple App Store or Google Play (Search "Brady Express Labels")**



Apple App Store



Google Play



Printer specifications

PRINTER	
Description	BMP51 Label Printer
Includes	This printer ships in a hard case with a Rechargeable Lithium Ion Battery, USB Cable, AC adaptor, power cord, Product CD, Brady Printer Drivers CD, Quick Start Guide, a Bluetooth network card and an MC1-1000-422 cartridge.
Applications	Data and telecommunications labelling Electrical labelling General identification Laboratory labelling Wire and cable labelling
Print Speed (mm/sec)	25.40 mm/s
Internal Memory Capacity	48 MB (stores up to 25,000 labels)
Cutter	Manual cut Between labels or at end of print job With label retention
Keyboard Type	QWERTY
Colour Capability	Monocolour
Language Support	Danish, Dutch, English, Finnish, French, German, Italian, Norwegian (Bokmål), Portuguese, Spanish, Swedish
Weight (kg)	1.18 kg
Dimensions	155.00 mm (W) x 261.62 mm (H) x 91.44 mm (D)
Drop Test	Resistant to 1.8 metre drops
Operating Temperature	4°C - 43°C
Operating Humidity	20%-90% (non-condensing)
Warranty	2 years

MEDIA SUPPORTED	
Materials Supported	FreezerBondz™ Polyester Heat-shrink Polyolefin Metallised Polyester Nylon Cloth Paper Polyester Polypropylene Reflective Tape Self-laminating Polyester Self-laminating Vinyl StainerBondz™ Polyester Tamper-resistant Vinyl Vinyl Vinyl Cloth
Compatible Media	M-, MC-, MC1-, MFT-, M4-, M4C-, M5-, M5C-
Continuous vs Die-cut Labels	Continuous and Die-cut
Custom Labels	No
Smart Cell	Yes
Calibration	Automated through Smart Cell
Max. Label Width (mm)	38.10 mm
Min. Label Width (mm)	6.00 mm
Recommended Usage per Day	500

POWER SUPPLY	
Auto Shut Off	10 minutes User Configurable
Battery Type	Rechargeable Lithium-ion Battery (8) AA Alkaline
Power Supply	Batteries Rechargeable Battery AC Adaptor

DISPLAY	
Display	Monocolour LCD Screen
Display Resolution	320 x 240 pixels
Display Size	68.58 x 43.18 mm

FONTS/GRAPHICS/SYMBOLOLOGIES	
Text Sizes (pt)	4 - 103 pt
Built-in Fonts	Brady Alpine Brady Fixed Width
Built-in Symbols	450
Symbol Categories	Arrows Electrical Exit Datacom Fire Safety First Aid GHS/CLP Laboratory Mandatory Packaging Miscellaneous Personal Protective Equipment Prohibition Public Information Safety Warning WHIMIS
Bar Code Type	Code 128, Code 39, More through Brady WorkStation, More through Brady Workstation

PRINTING FUNCTIONS	
Printing Functions	Banner Serialisation Mirror Rotate Reverse Auto Format Justification Vertical Fixed Length Multi-copy Print Preview Date/Time Stamp Frame Feature
Serialisation	Simple & Simultaneous & Single Advanced & Multiple Advanced
Printing Modes	Flags Terminal Block Patch Panel Wire Wrap
Print Resolution (dpi)	300 dpi

SOFTWARE & CONNECTIVITY	
Connectivity Options	Bluetooth Ethernet (optional) USB
Software Compatibility	Brady Workstation Express Labels Mobile App

COMPLIANCE	
Approval/Compliance	CE WEEE RoHS

BMP51 Printer, kits and accessories

Printers

Order Reference	Art. No.	Description
BMP51 PRINTER EU	710894	BMP51 Label Printer - EU
BMP51-EU-LABS	306856	BMP51 Label Printer - EU with Brady Workstation LAB Suite
BMP51-EU-PWID	198630	BMP51 Label Printer - EU with Brady Workstation PWID Suite
BMP51 PRINTER KIT UK	710898	BMP51 Label Printer - UK
BMP51-UK-LABS	306857	BMP51 Label Printer - UK with Brady Workstation LAB Suite
BMP51-UK-PWID	198631	BMP51 Label Printer - UK with Brady Workstation PWID Suite

 The Brady Workstation Basic Suite is included with every printer, all you need to do is download it.

 The BMP51 is also available with specialised Workstation suites for Product and Wire Identification and Laboratory Identification.

 You'll find the necessary download information in a booklet that comes with your printer.



Printer Kits

Order Reference	Art. No.	Description
BMP51-EU-ELEC*	198654	BMP51 Electrical Kit EU
BMP51-UK-ELEC*	198657	BMP51 Electrical Kit UK
BMP51-LAB*** KIT-EU	198655	BMP51 Laboratory Kit EU
BMP51-LAB*** KIT-UK	198658	BMP51 Laboratory Kit UK
BMP51-EU-DATA**	198653	BMP51 TeleDatacom Kit EU
BMP51-UK-DATA**	198656	BMP51 TeleDatacom Kit UK

*This printer ships in a hard case with a Rechargeable Lithium Ion Battery, USB Cable, AC adaptor with power cord, Magnet accessory, Product CD, Brady Printer Drivers CD, Quick Start Guide, a Bluetooth network card, a Brady Workstation Product & Wire Identification Suite, M-48-427, MC-375-422 and an MC1-1000-422 cartridge.

**This printer ships in a hard case with a Rechargeable Lithium Ion Battery, USB Cable, AC adaptor with power cord, Magnet accessory, Product CD, Brady Printer Drivers CD, Quick Start Guide, a Bluetooth network card, a Brady Workstation Product & Wire Identification Suite, M-132-499, M1-115-427 and an MC1-1000-422 cartridge.

***This printer ships in a hard case with a Rechargeable Lithium Ion Battery, USB Cable, AC adaptor with power cord, Product CD, Brady Printer Drivers CD, Quick Start Guide, a Bluetooth network card, a Brady Workstation LAB Suite, M-122-461, M-131-499 and an MC1-1000-422 cartridge.



Accessories

Art. No.	Order Reference	Description
142261	BMP-UBP-AC	Univeral Li-ion Battery Pack with AC Adaptor/Battery Pack US
710902	UBP-Li-ION-AC-EUR	Univeral Li-ion Battery Pack with AC Adaptor/Battery Pack EU
710903	UBP-Li-ION-AC-UK	Univeral Li-ion Battery Pack with AC Adaptor/Battery Pack UK
114883	M41/50/61/71/611-AC-BC-NA	AC Adaptor, USA 120V
710612	M41/50/61/71/611-AC-BC-EU	AC Adaptor, Europe 220V
710613	M41/50/61/71/611-AC-BC-UK	AC Adaptor, UK 240V
142260	BMP-UBP 12V	Rechargeable Lithium Ion battery for the BMP51 printer
143115	M50-BATT-TRAY	BMP50 Series Spare Battery Tray for 8 AA batteries
143109	M50-HC	BMP50 Series Hard Carry Case
150617	BMP-SC-1	Protective softbag for portable printers for M211; M210; BMP21; BMP51
143108	M50-MAGNET	BMP50 Series Magnet Accessory
142267	NET-LAN	LAN Network Card



Magnet

2 year warranty on all Brady portable printers

Brady offers a 2 year warranty on every Brady Mobile Printer sold. This manufacturer's warranty is completely free and highlights Brady's commitment to quality and on-the-job reliability.

▶ Flash this QR Code to access to all the details about the Brady warranty.



What if you want more extensive support ?

Brady offers Assist Base, Assist Field and Assist Custom service contracts which include priority assistance for 1, 3 or 5 years to guarantee continued support and the ultimate printer reliability, even in demanding working environments. These agreements also include many great extras versus our free, standard 2 year warranty, such as: spare parts, a solution within 2 business days, free annual preventive maintenance, repair transportation costs, priority access to the technical service team or even a specialist at your premises. Get all of these extra assurances for less than the cost of one flat fee repair!



Our training and setup service

- **Brady Setup Base** : Stress free installation of your Brady printer and software by screensharing. We help you produce your first labels.
- **Brady Setup Field** : Stress free installation of your Brady printer and software by a Brady specialist at your premises. We help you produce your first labels.
- **Brady Training Half/Whole day** : Hands-on training by a Brady specialist at your premises.

Please contact us for additional information!

▶ Register your product

After registering your product you will have access to:

- Technical support
- Notification of updates
- Special offers and product announcements

www.bradyeurope.com/registration





Belgium & Luxembourg

+32 (0) 52 45 78 11
benelux@bradycorp.com

Czech Republic

+420 776 302 229
czechrepublic@bradycorp.com

Denmark

+45 66 14 44 00
denmark@bradycorp.com

France

+33 (0) 3 20 76 94 48
france@bradycorp.com

Germany, Austria & Switzerland

+49 (0) 6103 7598 660
germany@bradycorp.com

Hungary

+36 23 500 275
hungary@bradycorp.com

Italy

+39 02 26 00 00 22
italy@bradycorp.com

Netherlands

+31 (0)70 323 62 98
benelux@bradycorp.com

Norway

+47 70 13 40 00
norway@bradycorp.com

Poland

+48 22 104 6262
poland@bradycorp.com

Qatar, Saudi Arabia & UAE

+971 4881 2524
me@bradycorp.com

Slovakia

+421 902 939 406
slovakia@bradycorp.com

South Africa

+27 11 704 3295
africa@bradycorp.com

Spain & Portugal

+34 900 902 993
spain@bradycorp.com
portugal@bradycorp.com

**Sweden, Finland, Estonia, Latvia,
Lithuania**

+46 (0) 8 590 057 30
sweden@bradycorp.com

Turkey

Istanbul
+90 212 264 02 20
turkey@bradycorp.com

UK & Ireland

+44 (0) 1295 228 288
uk@bradycorp.com

Our mission is to identify and protect people,
products and premises



To help minimise our impact on the environment,
Brady limits its number of reprints.

Updated versions are always available for
download on www.bradyeurope.com.



Search for: EUR-M-409-EN



Y1863893

Your distributor

Adva-Tech

mail: info@adva-tech.eu

mail: zamowienia@adva-tech.eu